

## FSV-6B Forged Steel Globe Valve Socket Ended, Class-800

### Product Description

HSN 84818030

Product : Sant Forged Steel Globe Valve  
 Product Standard : conforming to BS 5352/API 602  
 Type of Pattern : Standard Bore  
 Pressure/Class /Rating : Class-800  
 Body Material cum standard : FCS (A 105)  
 Product Description : Bolted Bonnet O/S Yoke type Rising Stem  
 Type of Seat : Renewable Seat  
 Type of Disc : Renewable Disc  
 Trim : Type 410  
 Fasteners : Alloy Steel (Gr. B7/2H)  
 Gaskets : Spiral wound SS 304/(CAF/Graphite Filled)  
 End Details : Socket Welded Ends as per ASME B 16.11

### Testing & Certification

Body Test Pressure : 207 barg (3000Psig.) Hyd.  
 Seat Test Pressure : 152 barg(2200Psig.) Hyd. 6.9barg (100Psig.) AIR

Our Works' Test Certificate is furnished with every supply.



### Dimensions (in mm)

Nominal Size	Nominal Size (Inches)	F	H	øW	B	A
15	1/2	88±2	155	76	21.70	14
20	3/4	100±2	185	86	27.20	14
25	1	130±2	230	152	33.90	14
32	1.1/4	147±2	250	152	42.55	15
40	1.1/2	171±2	280	152	48.65	15

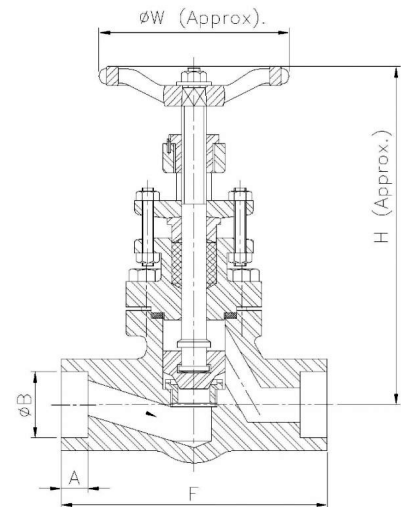

### Notes

1. Product images are for illustration purposes only. Actual product may vary.
2. Actual dimensions may change over time, due to continual design improvements. Please confirm before placing order.