

## FSV-9A Forged Steel Globe Valve Socket Ended, Class-1500

### Product Description

HSN 84818030

Product : Sant Forged Steel Globe Valve  
 Product Standard : Conforming to BS-5352/API 602  
 Pressure Class Rating : Class 1500  
 Body Material cum standard : FCS (A 105)  
 Product Description : Bolted Bonnet O/S Yoke Type Rising Stem  
 Type of Seat : Renewable Seat  
 Type of Disc : Renewable Disc  
 Trim : SS AISI-410  
 End Details : Socket Welded ends as per ASME B 16.11

### Testing & Certification

Body Test Pressure : 384 barg Hyd.  
 Seat Test Pressure : 281 barg Hyd., 6.9 barg (100 Psig) AIR  
 Our Works' Test Certificate is furnished with every supply.



### Dimensions (in mm)

Nominal Size	Nominal Size (Inches)	F	H (Approx)	B	A	W
15	1/2	88±2	155	21.70	14	70
20	3/4	100±2	185	27.05	14	86
25	1	130±2	230	33.80	15	152
40	1.1/2	171±2	280	48.65	15	152

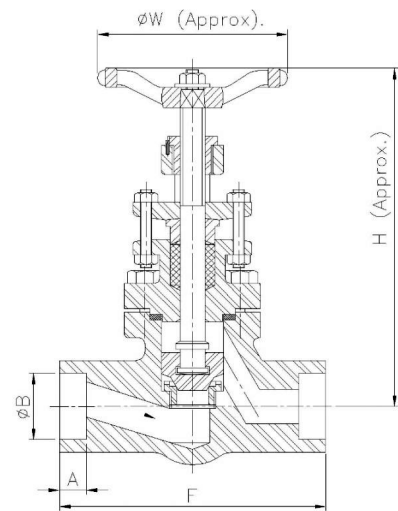

### Notes

1. Product images are for illustration purposes only. Actual product may vary.
2. Actual dimensions may change over time, due to continual design improvements. Please confirm before placing order.