

FBV2 Brass Ball Valve

Product Description

HSN 84818090

Product : Sant Forged Brass Ball Valve
 Pressure Rating : PN-25
 Body Material cum standard : Forged Brass
 Product Description : Two piece design lever operated
 Type of Seat : Renewable PTFE Seats
 Type of Ball : Brass (Nickel Plated)
 Stem: Machined Brass Nickel Plated
 Packing : PTFE
 Port Opening : Full Bore
 End Details : Screwed female BSP Parallel Threads



Testing & Certification

Body Test Pressure : 40kg/cm²g (Hyd.)
 Working Pressure : 25kg/cm²g (Hyd.)

Materials of Construction

Components	Materials	Specifications
Nut	S.S.	-
Gland	Brass	-
Gland Seal	PTFE	-
Connector	Forged Brass	IS:6912 FLB
Seat	PTFE	-
Ball	Forged Brass	IS:6912 FLB
Stem	Brass	-
Body	Forged Brass	IS:6912 FLB
Lever	Aluminum	-

Dimensions (in mm)

Nominal Size	Nominal Size (Inches)	F±2	LL (Approx.)
8	1/4	40	105
10	3/8	45	105
15	1/2	50	105
20	3/4	56	128
25	1	66	128
32	1 1/4	75	170
40	1 1/2	88	170
50	2	105	210
65	2 1/2	124	225
80	3	148	225
100	4	212	240

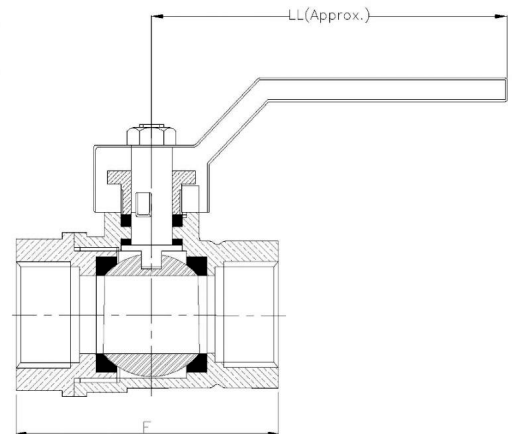

Notes