

## CI-17 Cast Iron Ball Valve Class 125, Screwed (ISI Marked)

### Product Description

HSN 84818030

Product : 'SANT' Cast Iron Ball Valve  
 Product Standard : IS:9890 Class 125  
 Type of Pattern : Straight  
 Body Material cum Standard : Cast Iron IS:210 Gr.FG220  
 Description : Two piece design  
 Type of Seat : Renewable Teflon  
 Trim : Stem: SS AISI-410, Ball: SS AISI-304  
 Gland Packing : Teflon Rings  
 End Details : Screwed female Parallel threads as per IS:554

**NOTE : Cover will be screwed in type for 50mm valve size & below**

### Testing & Certification

Body Test Pressure : 300 Psig. Hyd.  
 Seat Test Pressure : 220 Psig. Hyd., 100 Psig. Air

Our Works' Test Certificate is furnished with every supply.

### Application

Water	Oil	Gas
-------	-----	-----



### Materials of Construction

Components	Materials	Specifications
Body	Cast Iron	IS:210 Gr.FG220
Ball	Stainless Steel	AISI-304
Spindle	Stainless Steel	AISI-410
Body Seats & Gland Seals	Teflon	PTFE
Stopper, Gland Nut, Handle & Fasteners	Mild Steel	IS:2062:1992
Hand Sleeve	PVC	—

### Dimensions (in mm)

Nominal Size	Nominal Size (Inches)	F	LL (Approx.)
15	1/2	72±2	135
20	3/4	87±2	135
25	1	100±2	160
32	1.1/4	121±2	160
40	1.1/2	121±2	230
50	2	135±2	230
65	2.1/2	151±2	260
80	3	172±2	260
100	4	217±2	380

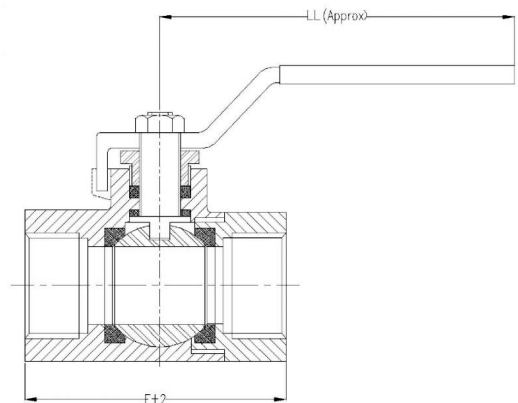

### Notes

1. Product images are for illustration purposes only. Actual product may vary.
2. Actual dimensions may change over time, due to continual design improvements. Please confirm before placing order.