

Globe Valve

SICCA 150-600 GLC

Class 150-600
NPS 2-10 Inches

Type Series Booklet



Legal information/Copyright

Type Series Booklet SICCA 150-600 GLC

All rights reserved. The contents provided herein must neither be distributed, copied, reproduced, edited or processed for any other purpose, nor otherwise transmitted, published or made available to a third party without the manufacturer's express written consent.

Subject to technical modification without prior notice.

© KSB Aktiengesellschaft, Frankenthal 13/12/2017

Contents

Globe Valves	4
Globe Valves to ANSI/ASME with Gland Packing	4
SICCA 150-600 GLC.....	4
Main applications.....	4
Fluids handled	4
Operating data.....	4
Body materials.....	4
Design details	4
Product benefits.....	5
Related documents	5
Purchase order specifications	5
Pressure/temperature ratings.....	6
Materials.....	7
Dimensions and weights.....	9
Notes on installation.....	9

Globe Valves

Globe Valves to ANSI/ASME with Gland Packing

SICCA 150-600 GLC



Main applications

- Boiler feed applications
- Fossil-fuelled power stations
- Petrochemical industry
- Pipelines and tank farms
- Refineries
- Process engineering

Fluids handled

- Service water
- Steam
- Fluids containing gas
- Gas
- High-temperature hot water
- Heating water
- Condensate
- Cooling water
- Fire-fighting water
- Fluids containing mineral oils
- Oil
- Lubricants
- Grey water
- Feed water
- Vacuum
- Thermal oil
- Wash water

Operating data

Operating properties

Characteristic	Value
Nominal pressure	Class 150 - 600
Nominal size [inch]	NPS 2 - 10
Max. permissible pressure [bar]	103
Max. permissible pressure [psi]	1500
Min. permissible temperature [°C]	≤ +593
Max. permissible temperature [°C]	≥ 0
Min. permissible temperature [°F]	≤ +1100
Max. permissible temperature [°F]	≥ 0

Selection as per pressure/temperature ratings (⇒ Page 6)

Body materials

Overview of available materials

Material	Temperature limit	
	[°C]	[°F]
ASTM A216 WCB	≤ 425	≤ 800
ASTM A217 WC6	≤ 593	≤ 1100
ASTM A351 CF8	≤ 537	≤ 1000
ASTM A351 CF8M	≤ 537	≤ 1000

Design details

Design

- Globe valve to BS 1873
- Cast steel body
- Hard-faced seat/disc interface (13 % chrome steel/Stellite)
- Bolted bonnet
- Outside screw
- Outside yoke
- Rotating stem
- Rising handwheel
- Flanged ends
- Butt weld ends
- Graphite gaskets and graphite packing with braided packing end rings offering wiping action
- Fully confined bonnet gasket
- Stem with burnished shank
- Two-piece self-aligning gland follower
- On/off disc
- Integral stem back seat
- Back seat bush made of hardened stainless steel
- Seat ring welded into body
- The valves satisfy the safety requirements of Annex I of the European Pressure Equipment Directive 2014/68/EU (PED) for fluids in Groups 1 and 2.
- The valves meet the requirements of the Indian Boiler Regulations 1950.

Variants

- Tapered valve disc
- Throttling plug
- Position indicator

- Design to API 623
 - Body guided disc
 - Locking device
 - Lantern ring
 - Bypass
 - Stem protecting tube
 - Electric actuators
 - Gearboxes
 - Limit switches
 - Drain plug
 - Drain branch
 - Special Class version for model with butt weld ends
- 8. Differential pressure
 - 9. Material
 - 10. Fluid handled
 - 11. Flow rate
 - 12. Pipe connection
 - 13. Pipe schedule
 - 14. Variants
 - 15. Reference number

Always indicate the original serial number and the year of construction when ordering spare parts.

Product benefits

- Long service life and high functional reliability
 - Two-piece self-aligning gland follower ensures even compression of packing rings.
 - Inconel-reinforced braided packing end rings offer smooth wiping action and prevent extrusion of graphite.
 - Hard-faced body seat made of wear-resistant and corrosion-resistant 13 % chrome steel or Stellite.
 - Burnished stem and smooth stuffing box surfaces extend the service life of the gland packing.
 - Rotating, self-aligning valve disc ensures reliable function.
 - Low actuating torque due to rolling element bearing on sizes 8 to 10 inches (Class 300) and 6 to 10 inches (Class 600).
- Additional features ensure safe sealing to atmosphere:
 - Additional safety and blow-out protection by standard back seat.
 - Fully confined cover gasket with controlled compression ensures leak-proof joint.
 - Die-formed endless graphite packing rings reliably seal the stem passage.
- Reliable, tight shut-off
 - High-grade surface finish: lapped seat/disc interface
- Economic benefits
 - Streamlined flow path minimises pressure losses.
 - Stem nut free from non-ferrous metals, for versatile application.

Related documents

Information/documents

Document	Reference number
Type series booklet SICCA 900-2600 GLC	7242.1
Operating manual	0500.80

Purchase order specifications

Please specify the following information in all enquiries or purchase orders:

1. Type
2. Class
3. Nominal size
4. Design pressure
5. Design temperature
6. Operating pressure
7. Operating temperature

Pressure/temperature ratings

Permissible operating pressures [bar] (in acc. with ASME B16.34 Standard Class)

Class	Material	[°C]																							
		-29 to +38	93	149	204	260	316	343	371	399	427	454	482	510	538	566	593	621	649	677	704	732	760	788	816
150	A216 WCB ¹⁾	20	18	16	14	12	10	9	8	7	6	5	3	2	1	-	-	-	-	-	-	-	-	-	-
300		51	47	45	44	42	39	38	37	35	28	22	16	9	6	-	-	-	-	-	-	-	-	-	-
600		102	94	90	87	83	78	76	73	70	57	44	32	19	12	-	-	-	-	-	-	-	-	-	-
150	A217 WC6 ²⁾³⁾	20	18	16	14	12	10	9	8	7	6	5	3	2	1	1	1	1	1	1	1	1	1	1	1
300		52	52	50	48	46	42	41	39	37	35	33	31	22	15	10	7	5	3	-	-	-	-	-	
600		103	103	100	96	92	83	81	78	73	70	67	62	44	30	20	13	9	6	-	-	-	-	-	-
150	A351 CF8 ⁴⁾	19	16	14	13	12	10	9	8	7	6	5	3	2	1	1	1	1	1	1	1	1	1	1	1
300		50	41	37	34	32	30	30	29	29	28	27	27	26	25	22	18	14	11	9	8	7	5	4	3
600		99	83	74	69	64	61	60	58	57	56	55	54	53	49	45	36	28	23	18	16	13	10	8	6
150	A351 CF8M ⁴⁾	19	16	15	13	12	10	9	8	7	6	5	3	2	1	1	1	1	1	1	1	1	1	1	1
300		50	43	39	36	33	31	30	30	29	29	29	29	27	25	25	21	16	13	10	8	7	5	4	3
600		99	86	77	71	66	62	61	60	59	58	58	57	57	53	50	42	33	26	20	16	13	10	8	6

Permissible operating pressures [psi] (in acc. with ASME B16.34 Standard Class)

Class	Material	[°F]																							
		-29 to +100	200	300	400	500	600	650	700	750	800	850	900	950	1000	1050	1100	1150	1200	1250	1300	1350	1400	1450	1500
150	A216 WCB ¹⁾	285	260	230	200	170	140	125	110	95	80	65	50	35	20	-	-	-	-	-	-	-	-	-	-
300		740	680	655	635	605	570	550	530	505	410	320	230	135	85	-	-	-	-	-	-	-	-	-	-
600		1480	1360	1310	1265	1205	1135	1100	1060	1015	825	640	460	275	170	-	-	-	-	-	-	-	-	-	-
150	A217 WC6 ²⁾³⁾	290	260	230	200	170	140	125	110	95	80	65	50	35	20	20	20	20	15	-	-	-	-	-	-
300		750	750	720	695	665	605	590	570	530	510	485	450	320	215	145	95	65	40	-	-	-	-	-	
600		1500	1500	1445	1385	1330	1210	1175	1135	1065	1015	975	900	640	430	290	190	130	80	-	-	-	-	-	-
150	A351 CF8 ⁴⁾	275	230	205	190	170	140	125	110	95	80	65	50	35	20	20	20	20	20	20	20	20	20	20	15
300		720	600	540	495	465	440	430	420	415	405	395	390	380	355	325	255	205	165	135	115	95	75	60	40
600		1440	1200	1075	995	930	885	865	845	825	810	790	780	765	710	650	515	410	330	265	225	185	150	115	85
150	A351 CF8M ⁴⁾	275	235	215	195	170	140	125	110	95	80	65	50	35	20	20	20	20	20	20	20	20	20	20	15
300		720	620	560	515	480	450	440	435	425	420	420	415	385	365	360	305	235	185	145	115	95	75	60	40
600		1440	1240	1120	1025	955	900	885	870	855	845	835	830	775	725	720	610	475	370	295	235	190	150	115	85

Test pressure

Test	Test medium	Class 150	Class 300	Class 600
		[bar]	[bar]	[bar]
Shell	Water	31	78	157
Back seat		22	57	114
Leak test (seat)		22	57	114

- 1) Permissible but not recommended for prolonged use above 427 °C (800 °F)
- 2) Use normalised and tempered materials only.
- 3) Cannot be used for temperatures above 593 °C (1100 °F)
- 4) At temperatures over 538 °C (1000 °F), use only when carbon content is 0.04% or higher.

Materials

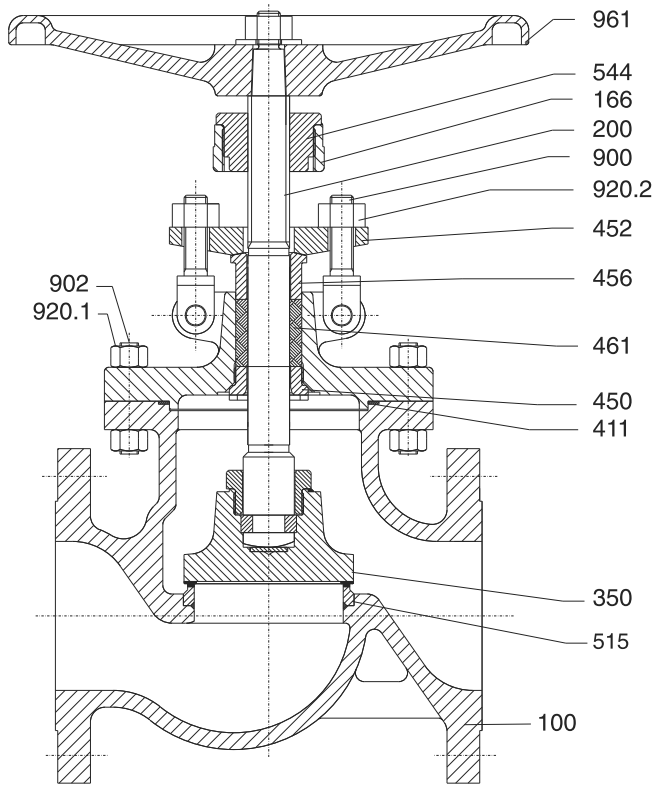

SICCA 150-600 GLC

Parts list

Part No.	Description	Material
100	Body	A216 WCB
		A217 WC6
		A351 CF8
		A351 CF8M
166	Yoke	A216 WCB
		A217 WC6
		A351 CF8
		A351 CF8M
200	Stem	A276 304
		A276 316
		A479 410-2
350	Valve disc	A216 WCB + 13 % Cr
		A217 WC6 + ST6
		A351 CF8
		A351 CF8M
411	Gasket	SS 316 + graphite
450	Back seat bush	A276 304
		A276 316
		A276 410 (H)
452	Gland flange	A105
		A182 F304
		A182 F316
456	Gland bush	A276 304
		A276 316
		A276 410
461	Gland packing	Graphite
515	Seat ring	A105+ST6
		A182 F11 + ST6
		A182 F304
		A182 F316
544	Threaded bush	A439 D2

Part No.	Description	Material
900	Eyebolt	A182 F304
		A307 B
902	Stud	A193 B7
		A193 B8
		A193 B8M
		A193 B16
920.1	Nut	A194 2H
		A194 4/7
		A194 8
		A194 8M
920.2	Nut	A194 2H
		A194 8
		A194 8M
961	Handwheel	Carbon steel

Dimensions and weights

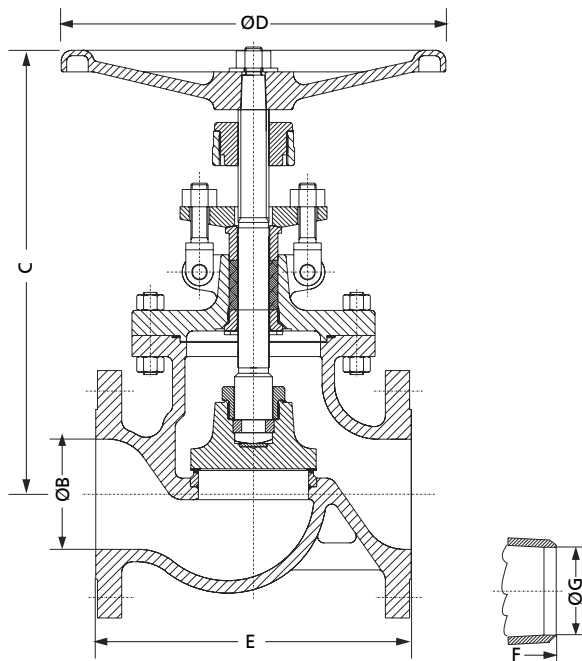

Dimensions and weights

Class	NPS	ØB	C ⁽⁵⁾⁽⁶⁾⁽⁷⁾	ØD	E	F ⁽⁸⁾	ØG ⁽⁸⁾	With flanged ends ⁽⁶⁾	With butt weld ends ⁽⁶⁾
	[inch]	[mm]	[mm]	[mm]	[mm]	[mm]	[mm]	[kg] ⁽⁷⁾	[kg] ⁽⁷⁾
150	2	51,0	350,0	203,0	203,0	203,2	52,5	25,0	20,0
	2 1/2	63,5	410,0	254,0	216,0	216,0	62,5	35,0	30,0
	3	76,0	420,0	254,0	241,0	241,3	78,0	40,0	40,0
	4	102,0	480,0	356,0	292,0	292,1	102,0	60,0	55,0
	5	127,0	545,0	356,0	356,0	356,0	128,0	75,0	65,0
	6	152,0	575,0	356,0	406,0	406,4	154,0	120,0	90,0
	8	203,0	685,0	457,0	495,0	495,3	203,0	145,0	130,0
	10	254,0	870,0	508,0	622,0	622,3	254,5	260,0	240,0
300	2	51,0	360,0	203,0	266,7	266,7	52,5	32,0	25,0
	2 1/2	63,5	430,0	254,0	292,0	292,0	62,5	45,0	40,0
	3	76,0	445,0	254,0	317,5	317,5	78,0	48,0	43,0
	4	102,0	520,0	356,0	355,6	355,6	102,0	75,0	65,0
	5	131,0	545,0	356,0	400,0	400,0	128,0	75,0	65,0
	6	152,0	620,0	457,0	444,5	444,5	154,0	135,0	120,0
	8	203,0	840,0	508,0	558,8	558,8	203,0	305,0	260,0
	10	254,0	910,0	508,0	622,3	622,3	254,5	375,0	315,0
600	2	51,0	415,0	254,0	292,1	292,1	49,2	45,0	40,0
	3	76,0	500,0	356,0	355,6	355,6	73,5	75,0	70,0
	4	102,0	570,0	356,0	431,8	431,8	97,0	110,0	100,0
	6	152,0	790,0	508,0	558,8	558,8	146,5	215,0	165,0
	8	200,0	920,0	610,0	660,4	660,4	193,5	540,0	500,0
	10	248,0	1140,0	610,0	787,4	787,4	243,0	790,0	720,0

Mating dimensions as per standard

Face-to-face lengths: ASME B16.10
 Flanges: ASME B16.5
 Butt weld ends: ASME B16.25

Notes on installation

The valve bodies are marked with an arrow indicating the flow direction.

Globe valves must always be installed in such a way that the actual flow direction of the fluid matches the arrow on the body, unless otherwise requested by the customer.

- 5) Open
 6) Dimensions and weights for design to API 623 variants on request.
 7) Approximate values
 8) Valves with butt weld ends: Schedule 40 for Class 150/300 and Schedule 80 for Class 600. Alternative schedules on request.



KSB Pumps Limited
151, NSN Palayam Post
Mettupalayam Road • Coimbatore - 641 031. (India)
Tel. : +91 422 2468222
Fax : +91 422 2468232
E-mail : contactusksbindia@ksb.com
www.ksbindia.co.in