

ECOLINE CDB-S

Centered disc butterfly valves



Design in accordance with EN 593

PN10 bar: DN50 to DN300

PN16 bar: DN50 to DN600

Applications

- General circuits: Water, Fuel, Oil and Gas.
- O.E.M
- Flow shut-off or regulation function in the sectors Including water supply, treatment, distribution, sewage and irrigation.

Working Conditions

- Temperature: from - 20 °C min up to +120 °C Max.
- Allowable pressure (PS):
 - 16 bar: DN 50 to 600 at ambient temperature- PN16 Series
 - 10 bar: DN 50 to 300 at ambient temperature- PN10 Series

Materials

- Refer Table.

Design

- Wafer type - PN10 Series - DN50 to DN 300
- Wafer type - PN16 Series - DN50 to DN 600
- Wafer type Lever operated: PN10 Series - DN50 to DN 300
- Wafer type Lever operated: PN16 Series - DN50 to DN 300
- Wafer type Gear operated: PN16 Series - DN50 to DN 600
- Mounting flange meets ISO 5211 standard for PN16
- Elastomer liner: an extra volume of rubber, located at the Shaft
- Passages areas, provides by compression between the Valve
- Body and the disc edge a perfect leak - tightness at the shaft Passages.
- Face- to- face dimensions in accordance with: ISO 5752 series 20 / EN 558- 1 series 20 / API 609 / MSS SP67 / EN 593
- Marking in accordance with EN 19.
- Anti-blow out stem retained by retainer plate.
- Self-centering disc ensures perfect upstream/zero leakage Visible to the naked eye.
- Valves perfectly tight shut- off (no visible leakage at the naked eye) in either flow direction, in accordance with the Following Standard: API598, EN 12266-1 leak level A and ISO 5208 category A.
- Design in accordance with EN 593 / MSS SP67 / API 609 / IS 13095
- Long neck execution for good insulation on PN 16 series
- Body coated with fusion bonded Epoxy for PN16 & Epoxy powder coated on PN10 series with thickness of 200 µm, Color light blue ref. RAL 5012 Confirms to water specifications.
- Discs in spheroidal graphite cast iron coated with Nylon 11 Polyimide paint of thickness 200 µm. RAL 7001 Suitable for drinking water
- No asbestos in any form in any items.

Standard Variants

- Pneumatic actuator
- Electric actuator
- Limit switches and Positioner
- Seat for Drinking Water application.
- Other disc material CF8 / AI.BZ.

Data to be supplied when ordering

- ECOLINE CDB-S series valve in accordance with type leaflet **8409.11/4-10**
- Size.
 - Nature of fluid.
 - Flow.
- Connection.
- Working conditions:
 - Pressure.
 - Temperature.
- Actuation

Materials

Model	Body	Disc	Stem
PN 10 Series, Wafer	Grey Cast Iron, EN 1561-GJL-250	EN 1563-EN-GJS-400-15	BS 970-EN 8
PN 16 Series, Wafer	Grey Cast Iron, EN 1561-GJL-250	EN 1563-EN-GJS-400-15	ASTM A276 420
PN 16 Series, Wafer	Grey Cast Iron, EN 1561-GJL-250	ASTM A351 CF8M	ASTM A276 420

Seat Code and Temperature Range

Code	Material	Temp ° C	
		Minimum	Maximum
Bb	Buna-N	-20° C	+80° C
Eh	EPDM	-20° C	+120° C
Vv	Viton	-10° C	+150° C
Hh	Hypalon	-10° C	+70° C
Ss	Silicone	-20° C	+150° C
Nn	Neoprene	-10° C	+90° C

Hydraulic characteristics

DN	NPS	Flow coefficient valve in fully open position		Zeta
		Kvo	Cvo	
50	2	133	154	0,56
65	2 ½	240	280	0,49
80	3	410	475	0,39
100	4	655	760	0,37
125	5	900	1 044	0,48
150	6	1 800	2 090	0,25
200	8	3 550	4 120	0,20
250	10	7 350	8 453	0,12
300	12	9 100	10 465	0,16
350	14	11 200	12 880	0,19
400	16	14 800	17 020	0,19
450	18	19 700	22 655	0,17
500	20	25 000	28 750	0,16
550	22	31 700	36 455	0,15
600	24	36 400	41 860	0,16

Operating Torques*

DN	NPS	10 bar (Lubricated)	10 bar (Non Lubricated)	16 bar (Lubricated)
50	2	9	13,5	11
65	2½	14	21	17
80	3	22	33	30
100	4	40	60	56
125	5	55	82.5	65
150	6	75	112	90
200	8	150	225	169
250	10	200	300	230
300	12	250	375	290
350	14	-	-	550
400	16	-	-	780
450	18	-	-	1099
500	20	-	-	1492
600	24	-	-	2576

* The safety factor for selection of actuator is included in the torque value.

Dimensions PN10 Bare Shaft Valve

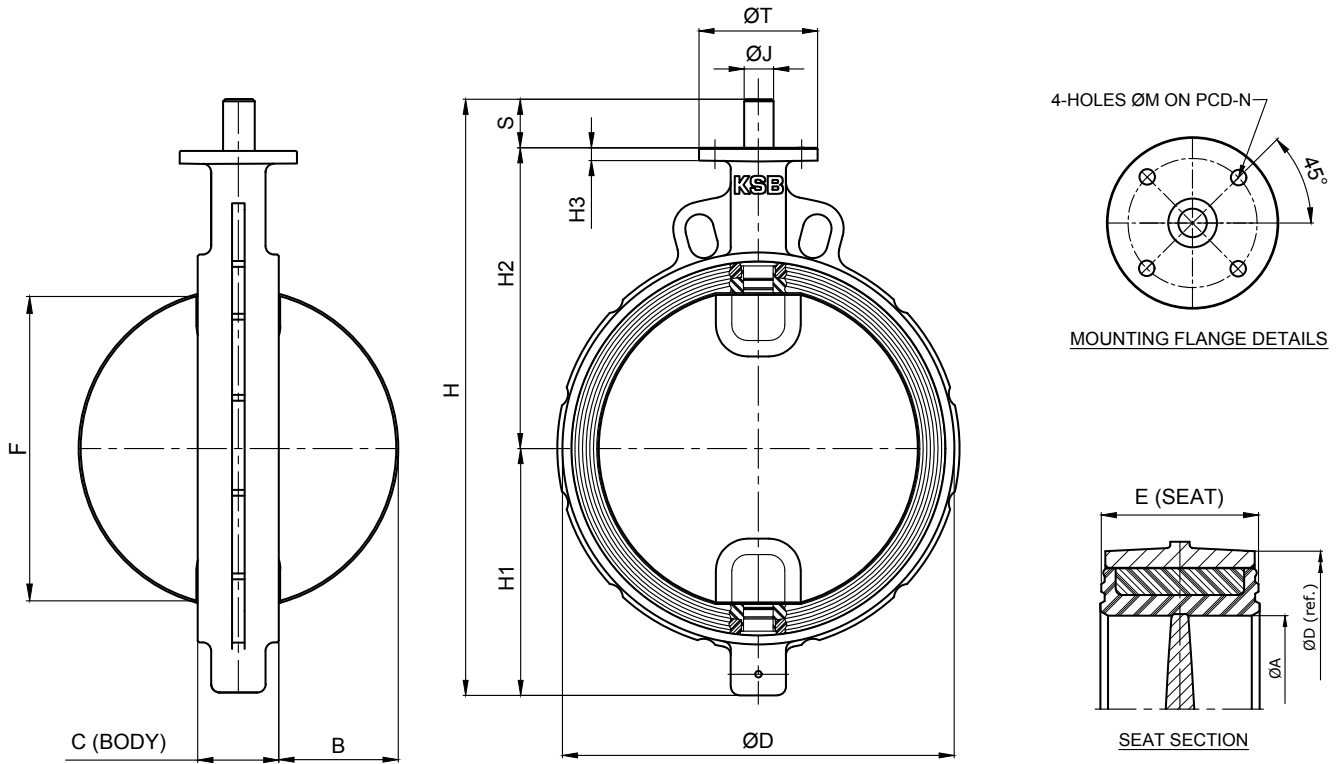

Valve size	øD	H1	H2	H3	H	S	C±0.5	E±0.5	F± 1	B± 1	øA	øM	N	øJ	øT	Wt. Kg
DN 50	93	74	100	10	197	23	42.0	46.0	34.0	6	52.4	7	56	9.95	70	1.6
DN 65	107	80	110	10	213	23	45.0	49.0	47.0	10	63.5	7	56	9.95	70	1.9
DN 80	130	94	116	10	233	23	45.0	49.0	66.0	17	77.8	7	56	11.95	70	2.4
DN 100	153	108	134	10	265	23	51.0	55.0	92.0	27	103	7	56	13.95	70	3.3
DN 125	188	122	165	10	310	23	55.0	59.0	118.0	37	128	7	56	16.95	70	5.0
DN 150	212	135	178	10	336	23	55.0	59.0	146.0	50	154	7	56	16.95	70	5.7
DN 200	270	164	212	12	411	35	59.0	63.0	195.0	74	204.8	12	90	22.95	112	11
DN 250	321	192	259	12	486	35	67.0	71.0	245.0	95	254.8	12	90	22.95	112	18.5
DN 300	382	233	284	12	552	35	77.0	82.5	295.0	114	303.5	12	90	25.97	112	23.5

PN10 series valve shall be supplied with lever only

Dimensions PN16 Bare Shaft Valve

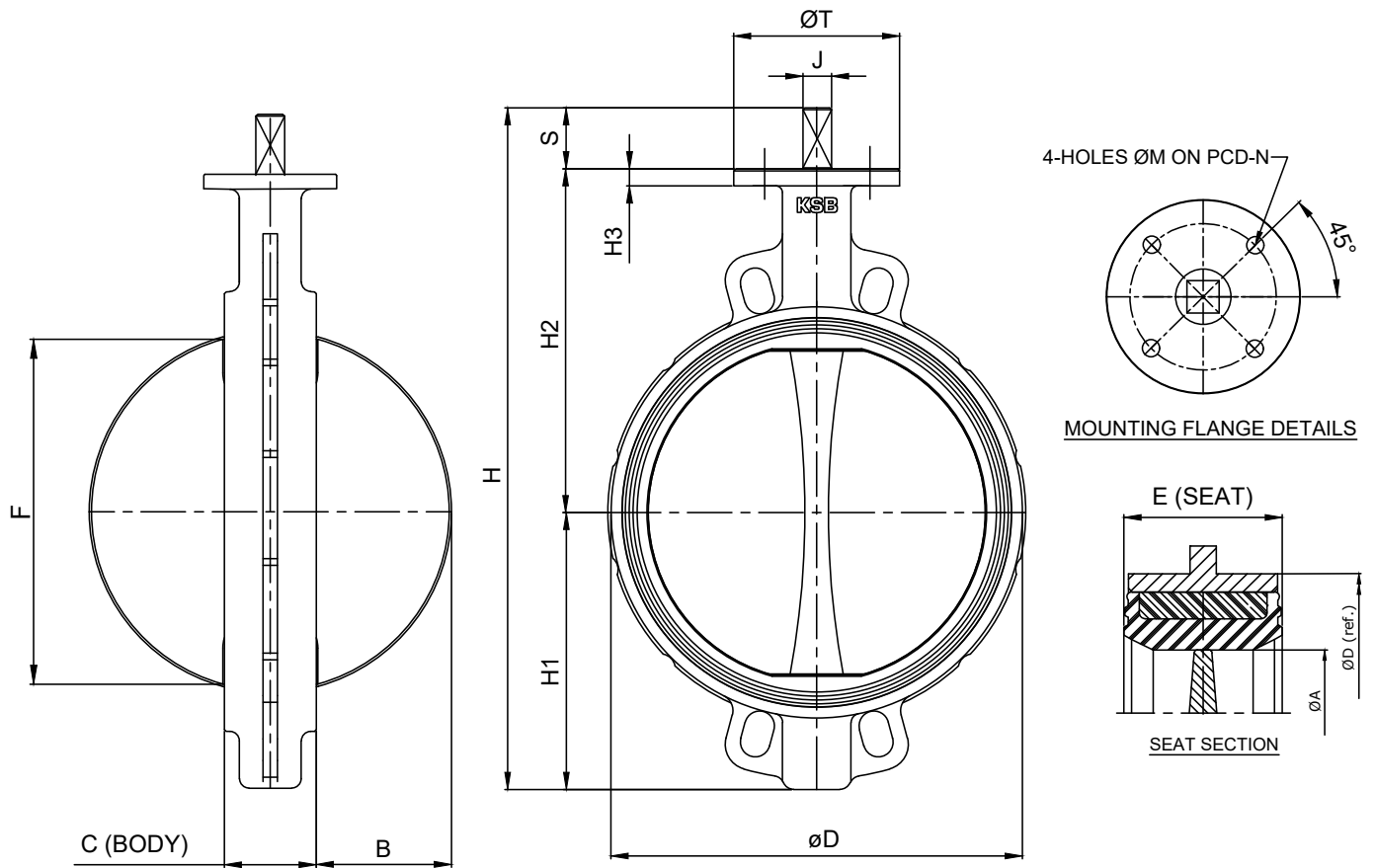

Valve size	øD	H1	H2	H3	H	C	E	F	B ±1	øA	øM	øN	ISO	Sq, J	øT	S	Wt. kg
DN 50	96	65	141	14.5	228	42	46	34	6	52.4	7/10	50 70	F05 F07	11	90	22	1.2
DN 65	109	71	153	14.5	246	45	49	47	10	63.5	7/10	50 70	F05 F07	11	90	22	1.7
DN 80	125	94	158	14.5	274	45	49	66	17	77.8	7/10	50 70	F05 F07	11	90	22	2.2
DN 100	151	108	176	14.5	306	51	55	92	27	103	10	70	F07	14	90	22	3.7
DN 125	181	120	191	14.5	333	55	59	118	37	128	10	70	F07	14	90	22	5.5
DN 150	206	136	203	14.5	361	55	59	146	50	154	10	70	F07	14	90	22	7.0
DN 200	261	165	244	15.5	444	59	63	195	74	204.8	12	102	F10	17	150	35	13.0
DN 250	316	202	273	15.5	510	67	71	245	95	254.8	12	102	F10	22	150	35	20.0
DN 300	372	233	311	15.5	579	77	82.5	295	114	303.5	14	125	F12	27	150	35	21.3
DN 350	436	267	368	20.0	670	77	82.5	325.2	130	332	14	125	F12	27	150	35	38.0
DN 400	488	302	405	25.0	742	102	106.5	380.8	145	389	18	140	F14	27	175	35	83.0
DN450	539	330	422	25.0	787	112	118	431.0	165	440.5	18	140	F14	27	175	35	91.5
DN500	593	367	490	25.0	903	127	132	476.4	181.4	485	18	140	F14	36	175	46	136.5
DN600	830	446	573	25.0	1074	152	160	580.0	219.3	590.5	23	165	F16	46	210	55	150.5

Dimensions of Lever

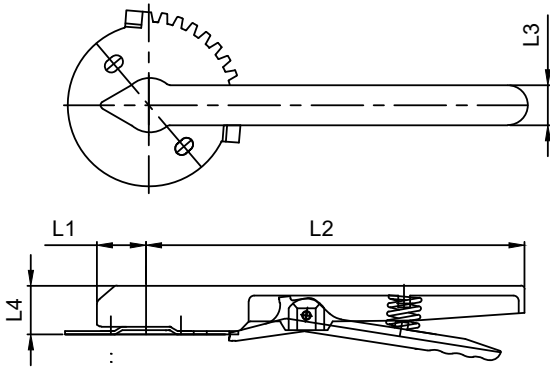

Valve size	L1	L2- PN10	L2- PN16	L3	L4	Wt. Kg
DN 50	26	245	260	26	32	1.3
DN 65	26	245	260	26	32	1.3
DN 80	26	245	260	26	32	1.3
DN 100	26	245	260	26	32	1.3
DN 125	26	245	260	26	32	1.3
DN 150	26	245	260	26	32	1.3
DN 200	46	351	351	37	49	2.8
DN 250	46	351	351	37	49	2.8
DN 300	46	351	351	37	49	2.8

Dimensions of Gear Box for PN 16 Series

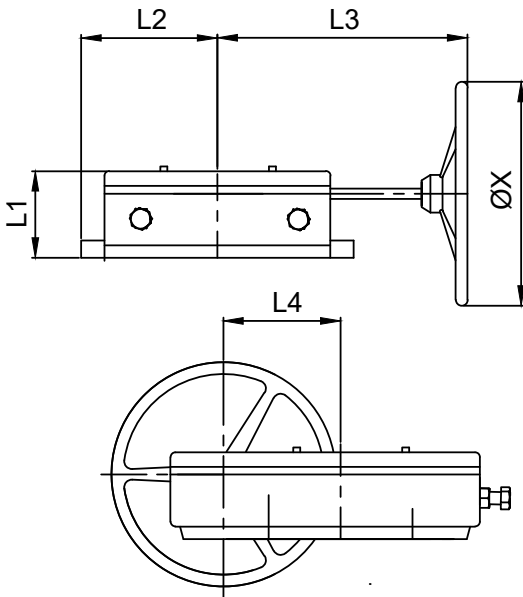

Valve Size	L1	L2	L3	L4	X	Gear box model	Wt. Kg
DN 50	62	48.6	209	48	300	QT35	5.0
DN 65	62	48.6	209	48	300	QT35	5.0
DN 80	62	48.6	209	48	300	QT35	5.0
DN 100	62	48.6	209	48	300	QT35	5.0
DN 125	62	48.6	209	48	300	QT35	5.0
DN 150	62	48.6	209	48	300	QT35	5.0
DN 200	71	56.0	209	56	300	QT50	6.0
DN 250	75	56.0	209	56	300	QT50	6.0
DN 300	60	86.0	320	78.5	400	QT100	14.5
DN 350	95	86	320	78.5	400	QT100	14.5
DN 400	78	105	341	105	500	QT250	23.5
DN 450	100	105	341	105	500	QT250	23.5
DN 500	113	105	341	105	500	QT250	23.5
DN 600	103	142.5	209	130	500	QT500	43.0

Standard Variants

ELECTRICAL ACTUATOR

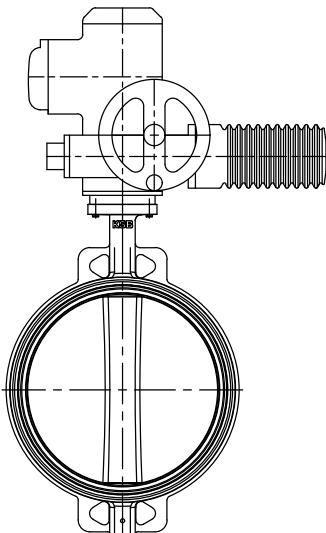

PNEUMATIC ACTUATOR

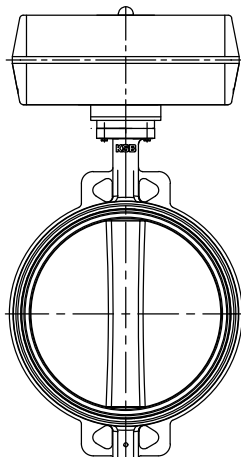

POSITIONER

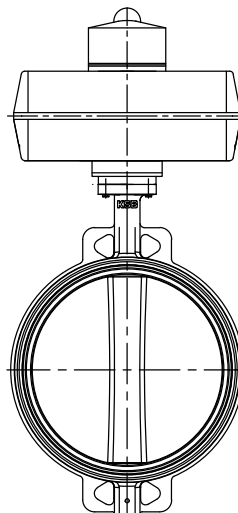

LIMIT SWITCHES

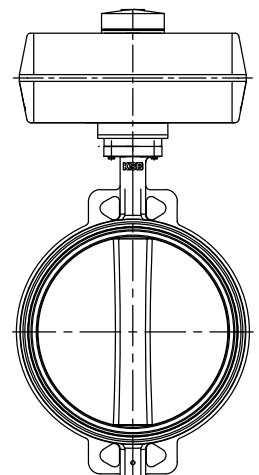

Material of Construction, PN10 series

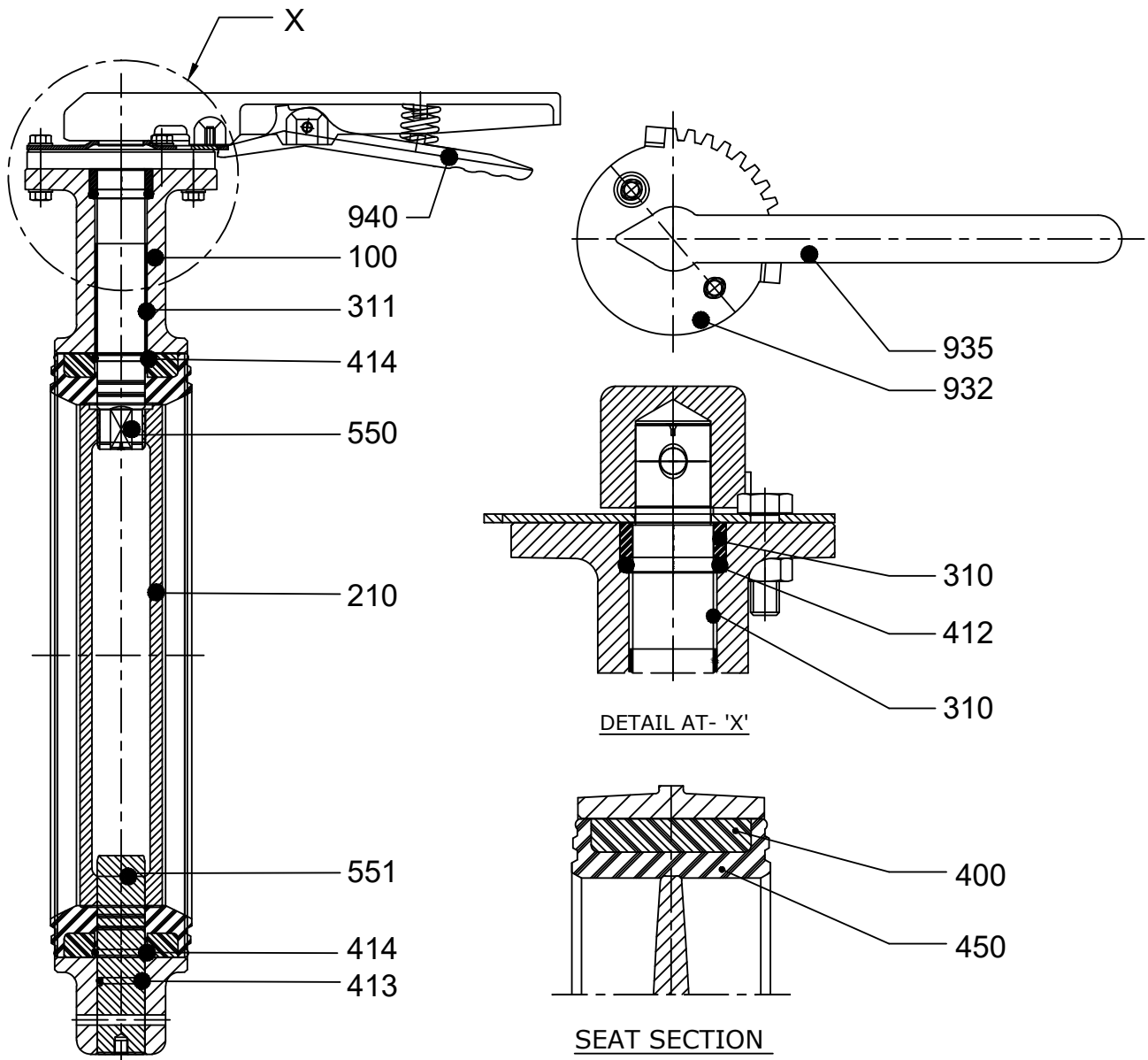

Item No	Description	Material
100	Body	Grey Cast Iron, EN 1561-GJL-250
550	Stem Top	BS 970-EN 8, Plated
551	Stem Bottom	BS 970-EN 8, Plated
310	Bearing	Nylon 6
311	Bush	Glass Fibre Filled Nylon
400*	Backup*	Bakalite/Aluminium
412	O' ring Body Top	EPDM / Buna-N
413	O' ring Body Bottom	EPDM / Buna-N
414	O' ring Seat Top & Bottom	EPDM / Buna-N
450	Seat	EPDM / Buna-N
210	Disc	En 1563-EN-GJS-400-15 (Nylon Coated)
932	Notch Plate	Mild Steel
935	Handle	Grey Cast Iron / Mild Steel
940	Lever	Grey Cast Iron / Mild Steel

*- For DN200 - DN300 Bush Material is Aluminium

DN50 - DN300

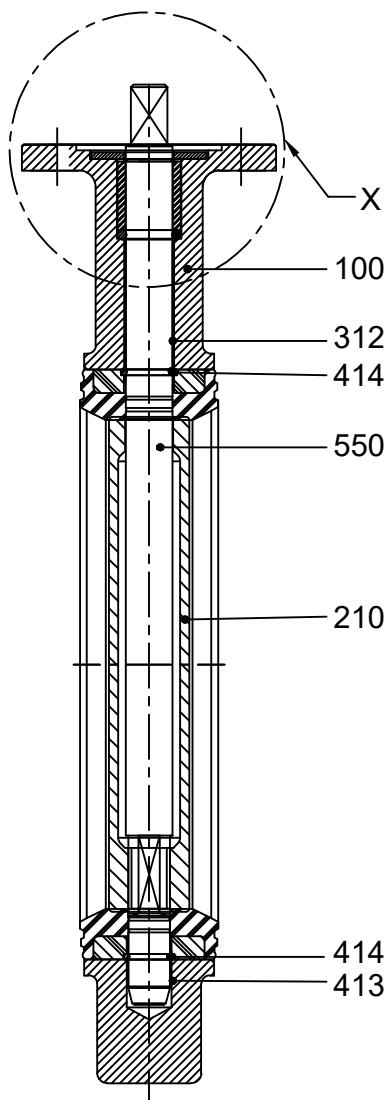

DN350 - DN600

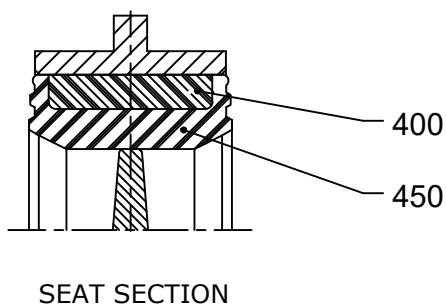
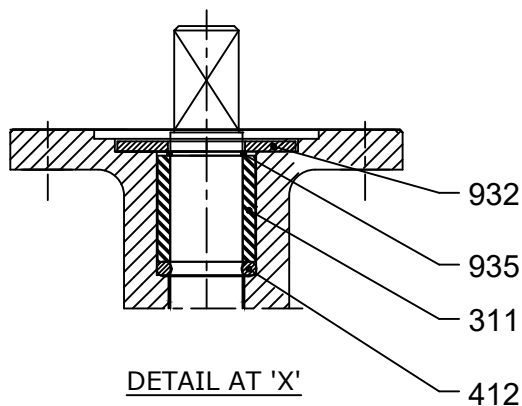
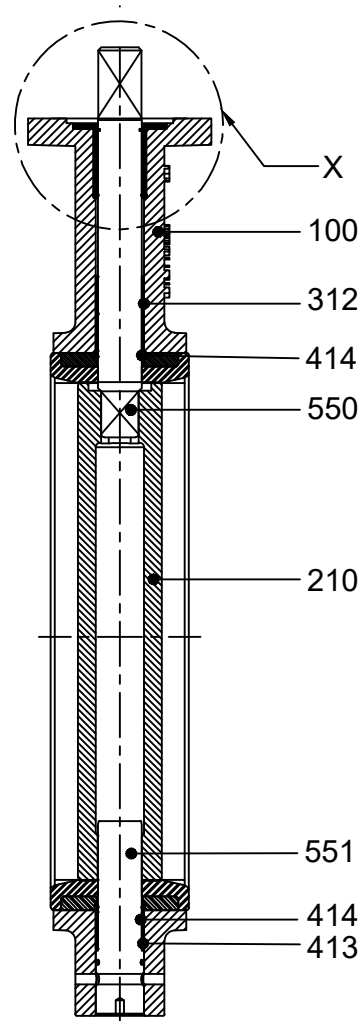

Item No	Description	Material
100	Body	Grey Cast Iron, En 1561-GJL-250
550*	Stem Top *	ASTM A276 420
551*	Stem Bottom *	ASTM A276 420
311**	Bush**	Glass Fibre Filled Nylon
312	Du Bush	PTFE With Metal
400***	Backup***	Bakalite / Aluminium
412	O'ring Body Top	EPDM / Buna-N
413	O'ring Body Bottom	EPDM / Buna-N
414	O'ring Seat Top & Bottom	EPDM / Buna-N
450	Seat	EPDM / Buna-N
210	Disc	En 1563-En-GJS-400-15 Or ASTM A351 CF8M
932	Retainer Plate	Mild Steel
935	Circlip	Spring Steel

*- For DN32 - DN300 single stem design.

**- For DN400 – DN600 Bush Material is Brass.

***- For DN200 – DN600 Ring Material is Aluminum

Flange bolt Connections

The ECOLINE CDB-S valves can be fitted between all the connections defined hereafter (Others connections on request).

Wafer Type - PN10 SERIES

DN	NPS	Connection					
		EN 1092		ASME		BS10	
		PN 6	PN 10	B16.1 cl. 125	B 16.5 cl. 150	Table D	Table E
50	2	✓	✓	✓	✓	✓	✓
65	2 ½	✓	✓	✓	✓	✓	✓
80	3	✓	✓	✓	✓	✓	✓
100	4	✓	✓	✓	✓	✓	✓
125	5	✓	✓	✓	✓	✓	✓
150	6	✓	✓	✓	✓	✓	✓
200	8	✓	✓	✓	✓	✓	✓
250	10	✓	✓	✓	✓	✓	✓
300	12	✓	✓	✓	✓	✓	✓

Fitting allowed

Wafer Type - PN16 SERIES

DN	NPS	Connection in accordance with standards					
		EN 1092		ASME		BS 10	
		PN 6	PN 10	B16.1 cl. 125	B 16.5 cl. 150	Table D	Table E
50	2	✓	✓	✓	✓	✓	✓
65	2 ½	✓	✓	✓	✓	✓	✓
80	3	✓	✓	✓	✓	✓	✓
100	4	✓	✓	✓	✓	✓	✓
125	5	✓	✓	✓	✓	✓	✓
150	6	✓	✓	✓	✓	✓	✓
200	8	✓	✓	✓	✓	✓	✓
250	10	✓	✓	✓	✓	✓	✓
300	12	✓	✓	✓	✓	✓	✓
350	14	✓	✓	✓	✓	✓	✓
400	16	✓	✓	✓	✓	✓	✓
450	18	✓	✓	✓	✓	X	✓
500	20	✓	✓	✓	✓	✓	✓
600	24	✓	✓	✓	✓	✓	✓

Fitting allowed

Pipe Flange Bolting for wafer type PN10 & PN16 series

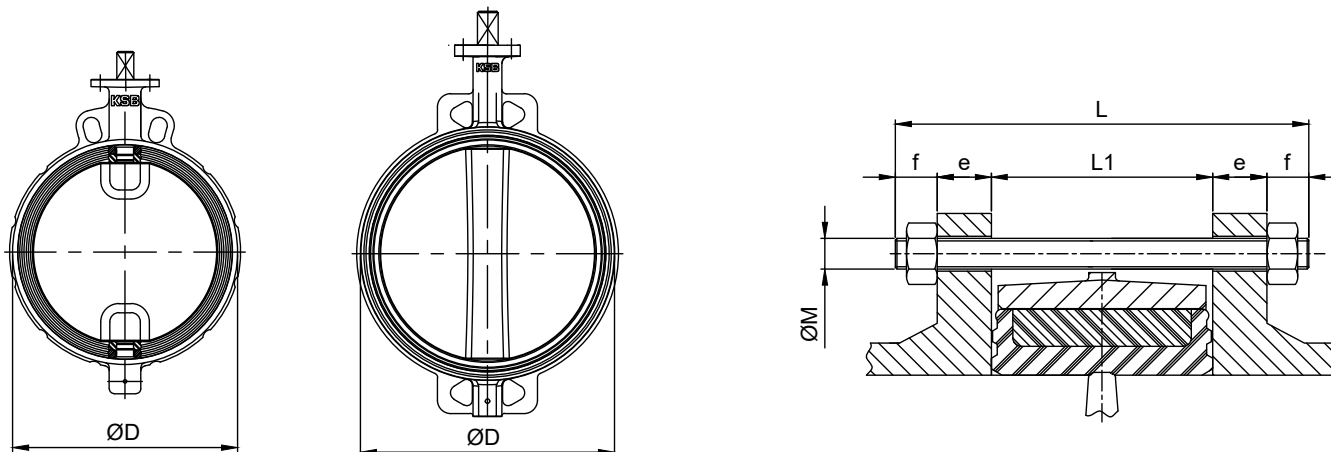

$$L = L1 + 2e + 2f$$

e: Flange thickness (customer specification)

L: Mini length of tie- rods

L1: Face to face of the valve

f: Nut thickness + over length of the tie- rod

Note: We do not supply the bolting

NPS	NPS	ØD	L1 Face to Face of Valve	EN 1092 PN 10			EN 1092 PN 16			ANSI B16- 1 class 125			ASME B16- 5 class 150		
				ØM	Tie- rod*		ØM	Tie- rod*		ØM	Tie- rod*		ØM	Tie- rod*	
					f	Qty		f	Qty		f	Qty		f	Qty
50	2	96	42.0	M16	20	4	M16	20	4	5/8"	20	4	5/8"	20	4
65	2 ½	109	45.0	M16	20	8	M16	20	8	5/8"	20	4	5/8"	20	4
80	3	125	45.0	M16	20	8	M16	20	8	5/8"	20	4	5/8"	20	4
100	4	151	51.0	M16	20	8	M16	20	8	5/8"	24	8	5/8"	24	8
125	5	181	55.0	M16	20	8	M16	20	8	3/4"	24	8	3/4"	24	8
150	6	206	55.0	M20	24	8	M20	24	8	3/4"	28	8	3/4"	28	8
200	8	261	59.0	M20	24	8	M20	24	8	3/4"	29	8	3/4"	24	8
250	10	316	67.0	M20	24	12	M24	29	8	7/8"	29	12	7/8"	29	12
300	12	372	77.0	M20	24	12	M24	29	12	7/8"	29	12	7/8"	29	12
350	14	436	77.0				M24	29	16				1"	32	12
400	16	488	102.0				M27	32	16				1"	32	16
450	18	539	112.0				M27	32	20				1"1/8	35	16
500	20	593	127.0				M30	35	20				1"1/8	35	20
600	24	830	152.0				M33	38	20				1"1/4	38	20

* Quantity nuts = quantity tie rods x 2

Flanging dimensions

ECOLINE CDB-S valves are designed for assembly between any type of flanges and connection standards currently used. The liner allows directly the tightness concerning the flanges. It is necessary to verify the general compatibility of the connection by checking against the dimensions shown in the table below.

The flanging dimensions mentioned in this table are the same for all types' body.

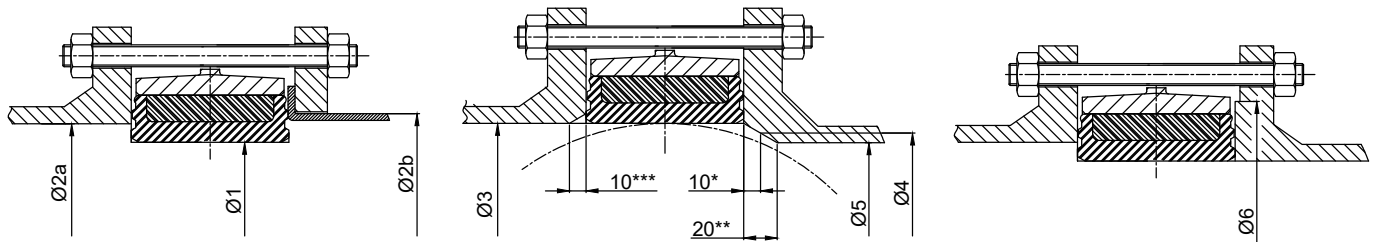

- $\varnothing 2a$ and $\varnothing 3$: diameter on the supporting area of the flange face.
- $\varnothing 2b$: external diameter of the butt-weld ends with lapped pipe end according to standards DIN 2642 and NFE 29-251. mm

DN	NPS	Opti- mum dia.	Max. dia tolerated	Min. dia. tolerated face of flange	Min. dia. 10 mm from face of flange	Min. dia. 20 mm from face of flange	Min. dia.	tolerated of shoulder of raised face flange
		$\varnothing 1$	$\varnothing 2a$	$\varnothing 2b$	$\varnothing 3$	$\varnothing 4$		
50	2	52.4	63	61	33	-----	-----	79
65	2 ½	63.5	80	77	55	13	-----	92
80	3	77.8	93	89	71	50	-----	110
100	4	103	116	115	90	74	40	135
125	5	128	141,5	140	119	107	87	164
150	6	154	170,5	169	144	134	120	188
200	8	205	222	220	196	189	178	245
250	10	255	276,5	273	249	243	234	300
300	12	304	327,5	324	297	291	283	353
350	14	332	361	356	326	321	314	375
400	16	389	412	407	370	366	358	432
450	18	440.5	463	457	422	416	409	483
500	20	485	515	508	470	464	457	532
600	24	590.5	617	610	566	560	554	655

Note: Please check the body is well centered between the tie - rods.

* - For DN150, DN250, DN300 consider 16mm.

* - For DN400, DN450, DN500, DN600 consider 26mm.

** - For DN400, DN450, DN500, DN600 consider 30mm.

***- For DN400 and above consider 10mm.

NB:

Direct fitting on rubber coated flange and with dilatation joint is not authorized.

Please, consult us.

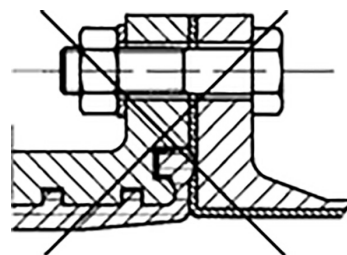

Rubber coated flange

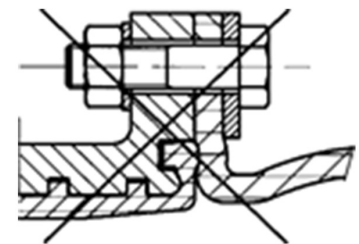

Dilatation joint

Product Features – to our customer’s benefit

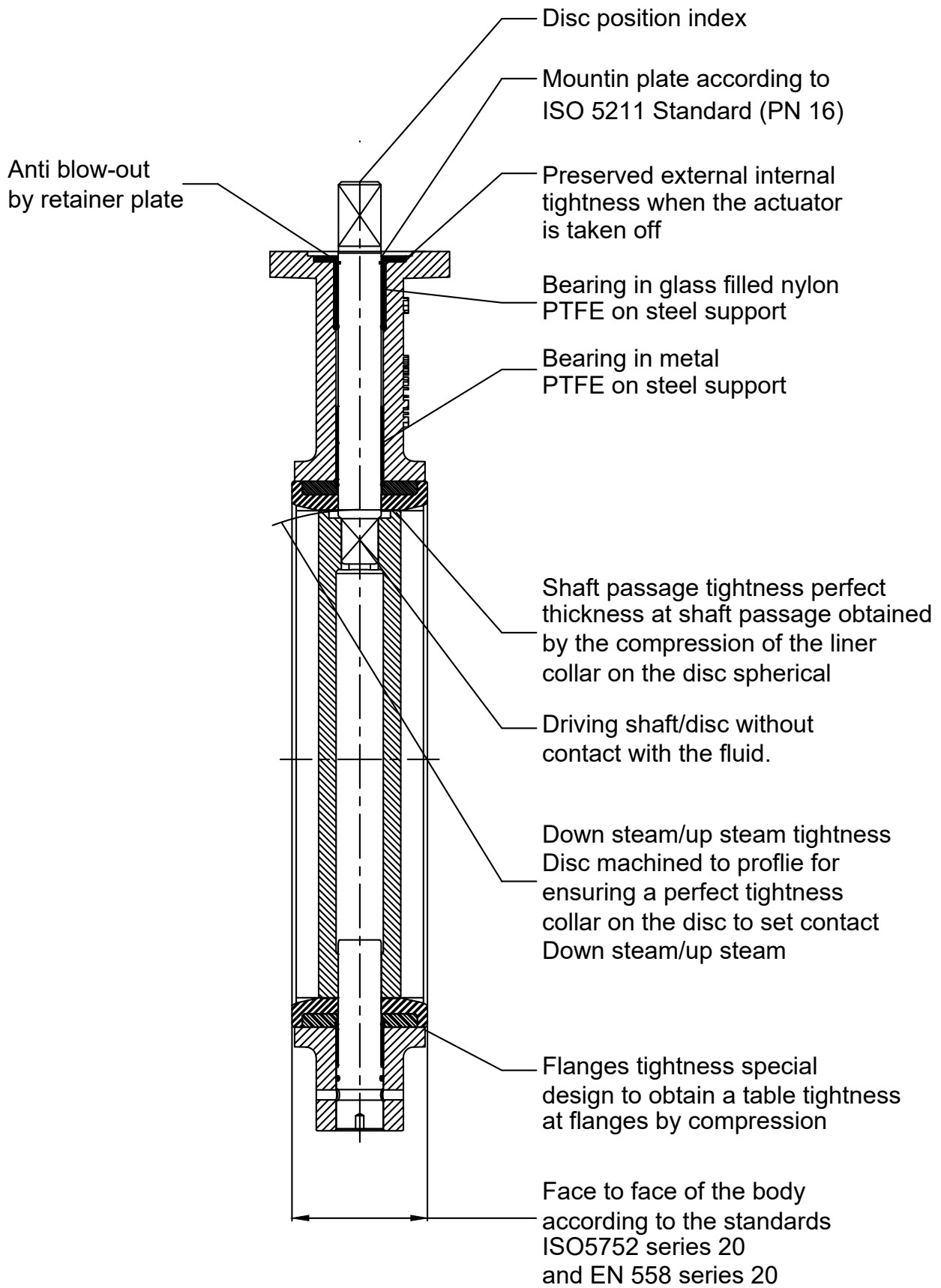

8409.11/4-10 Subject to technical modification without prior notice.



KSB Limited
Valves Division
 151, Mettupalayam Road, NSN Palayam Post, Coimbatore - 641 031.
 Tel.: 0422-2468222, 2468547-9 Fax : 0422-2468232 | www.ksbindia.co.in

Our toll free no : 1800 233 1299
 (Mon - Sat. 8 am to 10 pm)

Mktg. Services /12-19/500