

Applications

- Process and general industry
- For water, steam, gas, oil and other media
- Further applications on request

Operating data

- Maximum allowable pressure 1975 psi (136 bar)
- Maximum allowable temperature 392°F (200°C)
- Pressure/Temperature rating as per ASME B 16.34 (within the limits of the provided seat material).

Body Materials

- ASTM A 216 WCB Carbon Steel (Cast)
- ASTM A 351 CF8 Type 304 Stainless Steel
- ASTM A 351 CF8M Type 316 Stainless Steel
- ASTM A 105 Carbon Steel (Forged)

Ball Materials

- ASTM A 351 CF8 Type 304 Stainless Steel
- ASTM A 351 CF8M Type 316 Stainless Steel

Seat Material

- PTFE/RPTFE up to 392°F (200°C)

Design

- As per BS EN ISO 17292
- Pressure, Temperature rating as per ASME B 16.34 (within the limits of the provided seat material).
- Testing as per BS EN 12266
- Blowout proof stem
- Solid ball
- Socket weld ends as per ASME B 16.11
- Threaded ends to NPT/BSP as per ASME B 1.20.1 / BS 2779

Variants on Request

- Fire safe configuration
- Alternate Seats in RPTFE, PTFE + Graphite, Peek, Nylon, Acetal Resin
- Flanged Ends (150-300)
- Buttweld Ends
- Other material of construction

Remarks :

Other Type Series Booklets
ECOLINE BLT-S 150-300 : 8221.51/12-12
Operating Instructions : 8221.81/12-12

On all enquiries/orders please specify :

1. Valve type
2. ASME pressure class
3. Size
4. Design pressure
5. Design temperature
6. Operating temperature
7. Differential pressure-shut off
8. Flow medium
9. Material of construction
10. Variants
11. Type Series Booklet no.
12. Valve data sheet (if applicable)

When ordering spares, indicate valve serial number.

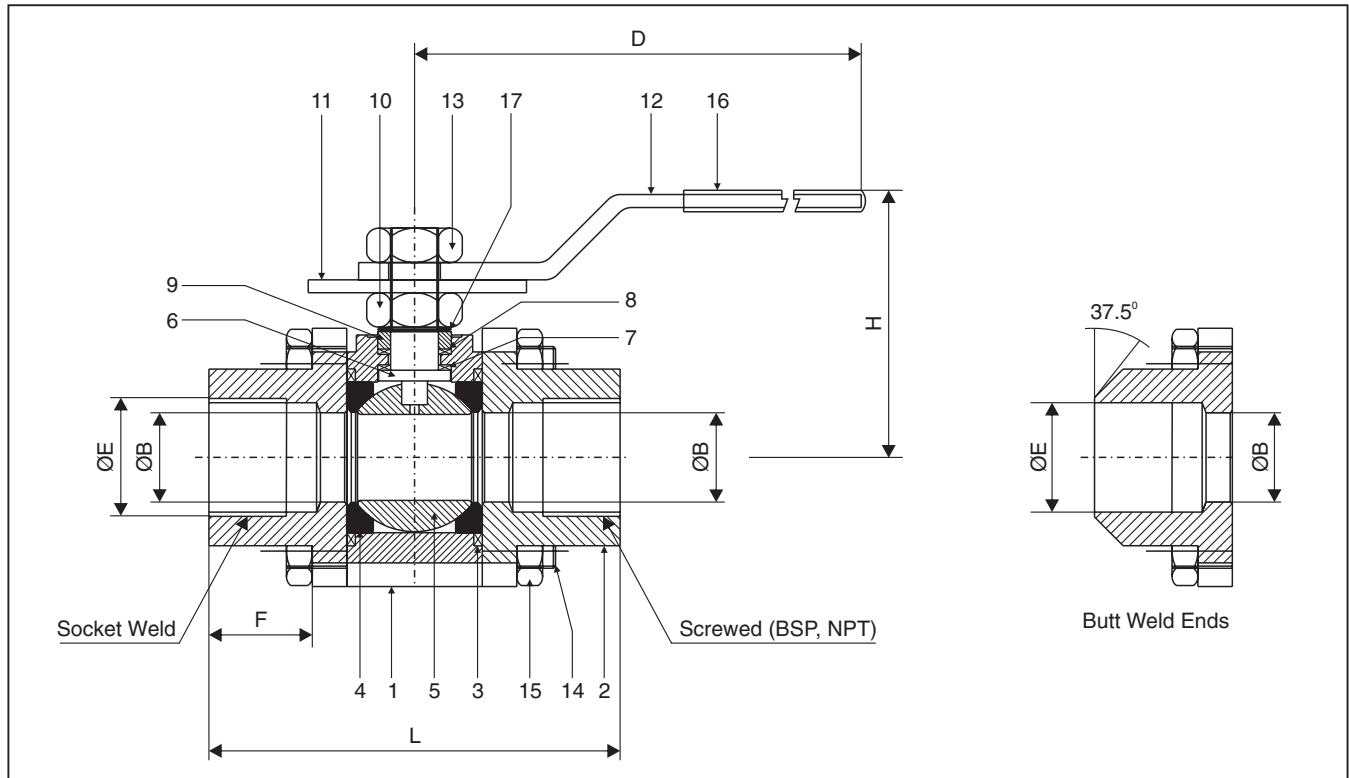

Design Specifications

- General valve design : BS EN ISO 17292
 Pressure, temperature rating : ASME B 16.34
 (within the limits of the provided seat material).
 Socket weld : ASME B 16.11
 Butt weld : ASME B 16.9
 End to end / : Manufacturer Standard
 Face to face dimension : Manufacturer Standard
 Testing standard : BS EN 12266

Dimensions in mm

Class - 400 & 800										
Size	Full Port				Regular Port				E	F
	L	B	H	D	L	B	H	D		
DN 15	72	14	48	114	69	11	45	114	21.72	13
DN 20	94	20	59	143	72	14	48	114	27.05	14
									27.30	
DN 25	101	25	65	143	94	20	59	143	33.78	17
									34.03	
DN 32	113	32	75	180	101	25	65	143	42.35	17
									42.80	
DN 40	127	38	81	180	113	32	75	180	48.64	18
									48.90	
DN 50	133	50	101	200	124	38	81	180	61.11	20

Material

Part No.	Description	Material			
1	Body	ASTM A	ASTM A	ASTM A	ASTM A
2	Body Connector	216 WCB	351 CF8	351 CF8M	105
3	Body Seal	PTFE	PTFE	PTFE	RPTFE
4	Ball Seat	PTFE	PTFE	PTFE	RPTFE
5	Ball	CF8M	CF8	CF8M	CF8M
6	Stem	SS316	SS304	SS316	SS316
7	Stem Seal	PTFE	PTFE	PTFE	RPTFE
8	Gland Packing	PTFE	PTFE	PTFE	RPTFE
9	Gland	SS316	SS304	SS316	SS316
10	Gland Nut	A194-2H	A194-8	A194-8M	A194-2H
11	Lock Plate	MS. Cd. Plated	MS. Cd. Plated	MS. Cd. Plated	MS. Cd. Plated
12	Lever	MS. Cd. Plated	MS. Cd. Plated	MS. Cd. Plated	MS. Cd. Plated
13	Lever Nut	A194-2H	A194-2H	A194-2H	A194-2H
14	Body Stud	A193-B7	A193-B8	A193-B8M	A193-B7
15	Body Nut	A194-2H	A194-8	A194-8M	A194-2H
16	Lever Sleeve	PVC	PVC	PVC	PVC
17	Disc Spring	Spring Steel	Spring Steel	Spring Steel	Spring Steel

Product features to our customer benefit

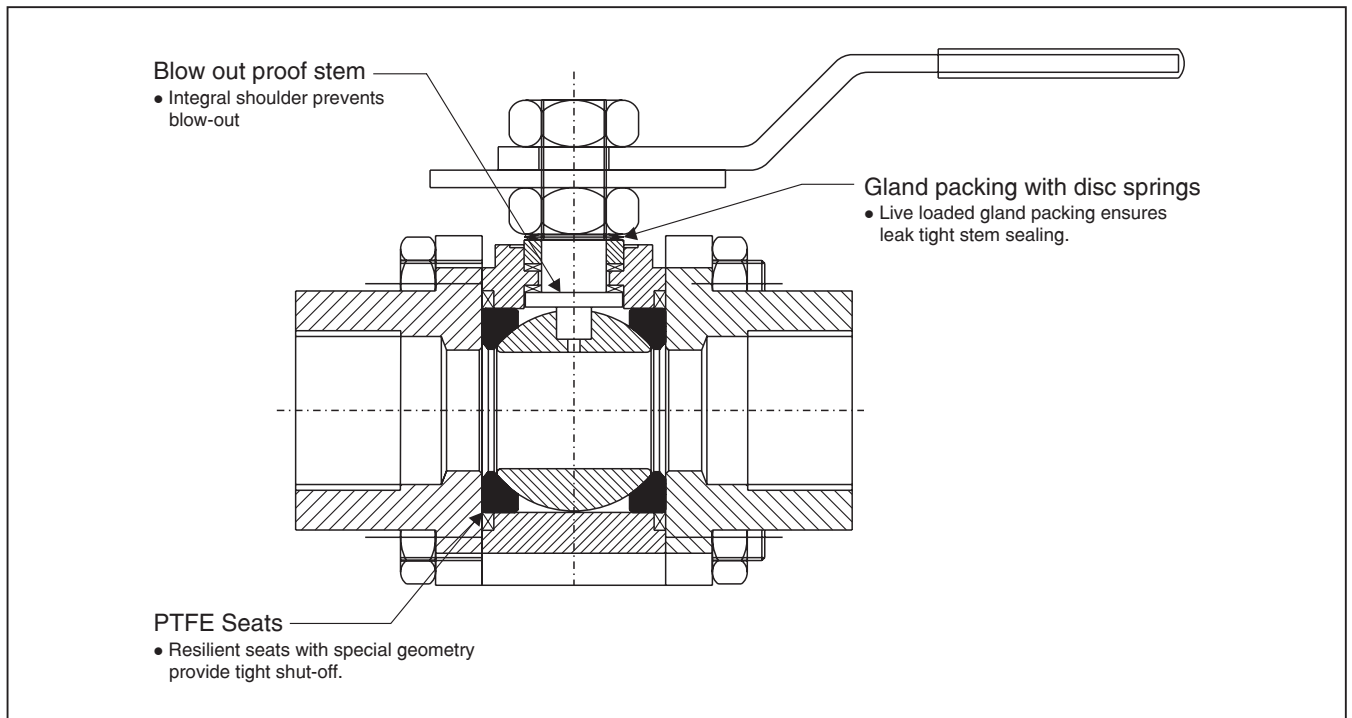

Blow-out Proof stem

Valves are of bottom entry stem design. The stem is inserted from inside the body and stem collar sits on the integral land provided in the body. Higher the line pressure, tighter will be the seal. This is a safety feature and does not allow stem to come out and eliminates possible accidents.

Stem seal with Disc springs

Stem packing consists of stem seal and gland packing rings (as per design requirement) which ensures leak tight stem sealing. Disc springs are pre-compressed and ensure that gland packing load is maintained on the stuffing box. This compensates the varying forces on the sealing gland due to changes in pressure and temperature. It also gives excellent thermal conductivity.

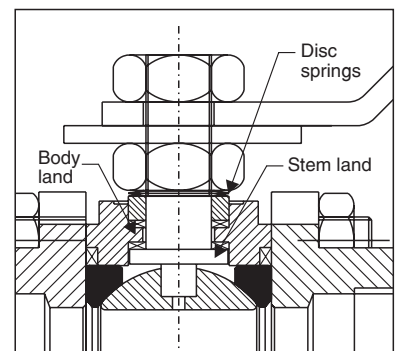

Floating Ball

In closed position, when the line pressure is acting on the upstream side ball, it moves/floats freely towards the down stream side seat giving effective tight sealing. In the open position, the fluid gets trapped in the body cavity and builds up the pressure. Hole provided on the ball prevents this and ensures no damage to the seats.

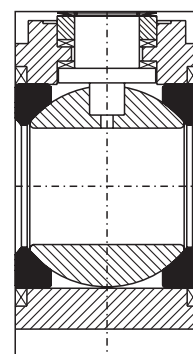

Test Specifications

Test	Medium	Class - 400		Class - 800	
		psi	bar	psi	bar
Shell	Water	1482	103	2963	205
Seat	Water	1087*	75*	2173*	150*
Seat	Air	85	6	85	6

* Seat test pressure will be as per the value given above or 1.1 times the rated seat pressure given in the Pressure/Temp. Graph, whichever is less.

Pressure Temperature Graphs

Pressure Temperature Rating : PTFE / RPTFE Seat

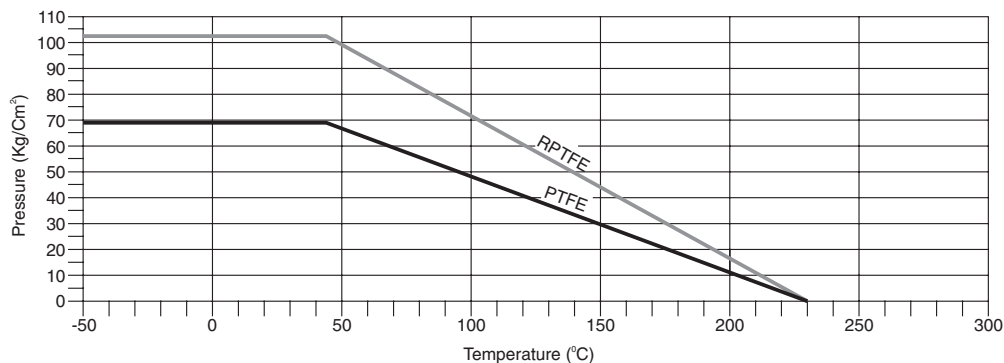

Pressure Temperature Rating : Peek Seat

(1) :- 15 to 25 FP / 15 to 40 RP
(2) :- 40 to 50 FP / 50 RP

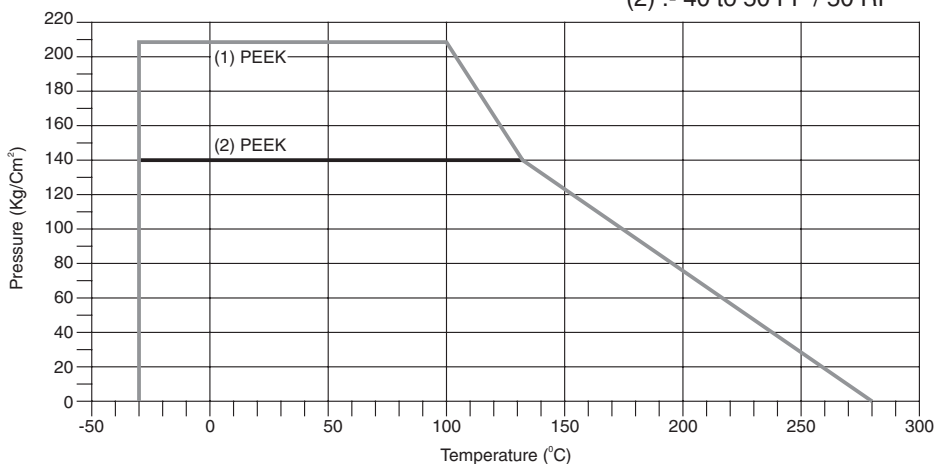

Pressure Temperature Rating : Nylon / Delrin Seat

(1) :- 15 to 25 FP / 15 to 40 RP
(2) :- 40 to 50 FP / 50 RP

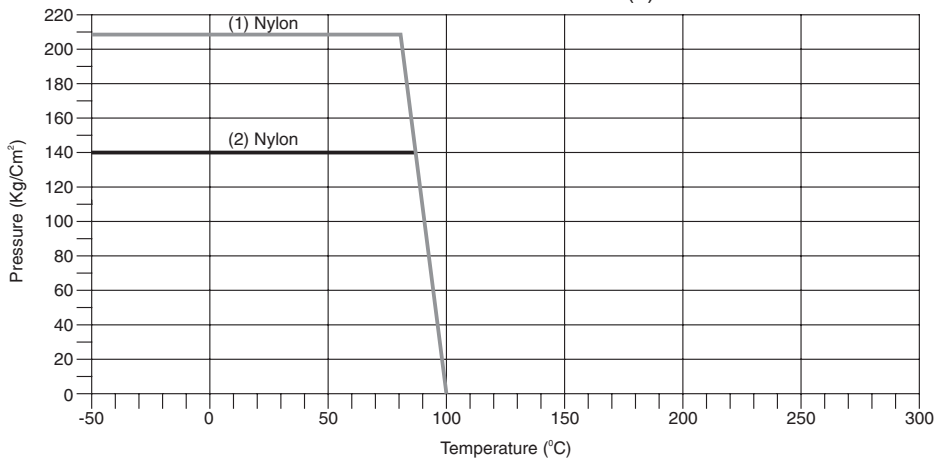

Technical matter subject to change without prior notice.



KSB Pumps Limited

151, Mettupalayam Road, NSN Palayam Post, Coimbatore 641 031. India.
Tel.: +91 422 2468222 Fax : +91 422 2468232 www.ksbindia.co.in