



## → Gate Valve

### Technical Specification

<b>Design Standard</b>	API 602 / ISO 15761
<b>Testing Standard</b>	API 598
<b>Face to Face Standard</b>	Manufacturer's Standard
<b>Socket Weld Standard</b>	ASME B16.11
<b>Screwed End Standard</b>	ASME B1.20.1
<b>Butt Weld Standard</b>	ASME B16.25
<b>Flange End Standard</b>	ASME B16.5

### Material of Construction

18	BACK SEAT	INTEGRAL	INTEGRAL	INTEGRAL	INTEGRAL	INTEGRAL
17	GLAND PACKING	FLEXIBLE GRAPHITE RINGS	FLEXIBLE GRAPHITE RINGS	FLEXIBLE GRAPHITE RINGS	FLEXIBLE GRAPHITE RINGS	FLEXIBLE GRAPHITE RINGS
16	HAND WHEEL	MI / SGIRON	MI / SGIRON	MI / SGIRON	MI / SGIRON	MI / SGIRON
15	NAME PLATE	STAINLESS STEEL	STAINLESS STEEL	STAINLESS STEEL	STAINLESS STEEL	STAINLESS STEEL
14	STEM NUT	ASTM A 194 GR. 2H	ASTM A 194 GR. 2H	ASTM A 194 GR. 2H	ASTM A 194 GR. 2H	ASTM A 194 GR. 2H
13	YOKE SLEEVE	ASTM A 582 GR. SS-416	ASTM A 582 GR. SS-303	ASTM A 582 GR. SS-303	ASTM A 582 GR. SS-416	ASTM A 582 GR. SS-303
12	EYE BOLT NUT	ASTM A 194 GR. 2H	ASTM A 194 GR. B8	ASTM A 194 GR. B8M	ASTM A 194 GR. 2H	ASTM A 194 GR. B8M
11	GLAND FLANGE	ASTM A 105	ASTM A 182 GR. F-304	ASTM A 182 GR. F-316	ASTM A 182 GR. F-22	ASTM A 182 GR. F-51
10	EYE BOLT	ASTM A 193 GR. B7	ASTM A 182 GR. F-304	ASTM A 182 GR. F-316	ASTM A 193 GR. B7	ASTM A 182 GR. F-316
09	GLAND BUSH	ASTM A 276 TYPE SS-410	ASTM A 276 TYPE SS-304	ASTM A 276 TYPE SS-316	ASTM A 276 TYPE SS-410	ASTM A 182 GR. F-51
08	EYE BOLT PIN	ASTM A 276 TYPE SS-410	ASTM A 276 TYPE SS-304	ASTM A 276 TYPE SS-316	ASTM A 276 TYPE SS-410	ASTM A 276 TYPE SS-316
07	HEX BOLT (*)	ASTM A 193 GR. B7	ASTM A 193 GR. B8	ASTM A 193 GR. B8M	ASTM A 193 GR. B16	ASTM A 193 GR. B8M
06	BONNET	ASTM A 105	ASTM A 182 GR. F-304	ASTM A 182 GR. F-316	ASTM A 182 GR. F-22	ASTM A 182 GR. F-51
05	GASKET (*)	SS-304 SPW+GRAPHITE	SS-304 SPW + GRAPHITE	SS-316 SPW+GRAPHITE	SS-304 SPW+GRAPHITE	SS-316 SPW+GRAPHITE
04	STEM	ASTM A 182 GR. F6a	ASTM A 182 GR. F-304	ASTM A 182 GR. F-316	ASTM A 182 GR. F6a	ASTM A 182 GR. F-51
03	WEDGE	ASTM A 217 GR. CA-15	ASTM A 351 GR. CF8	ASTM A 351 GR. CF8M	ASTM A 217 GR. CA-15	ASTM A 182 GR. F-51
02	SEAT RING	ASTM A 276 TYPE SS-410	ASTM A 276 TYPE SS-304	ASTM A 276 TYPE SS-316	ASTM A 276 TYPE SS-410	ASTM A 182 GR. F-51
01	BODY	ASTM A 105	ASTM A 182 GR. F-304	ASTM A 182 GR. F-316	ASTM A 182 GR. F-22	ASTM A 182 GR. F-51
	<b>DESCRIPTION</b>	<b>MATERIAL</b>	<b>MATERIAL</b>	<b>MATERIAL</b>	<b>MATERIAL</b>	<b>MATERIAL</b>
		MOC A 105	MOC F-304	MOC F-316	MOC F-22	MOC F-51

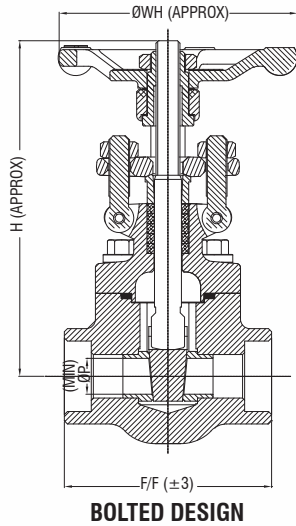

**Dimensions**

800#	15mm (1/2")	20mm (3/4")	25mm (1")	32mm (1-1/4")	40mm (1-1/2")	50mm (2")
F/F (mm)	73	80	100	120	120	130
ØP (mm)	9.5	12.7	17.5	23.8	28.6	36.5
H OPEN (mm)	151	157	186	237	237	268
H CLOSE (mm)	135	137	162	201	201	223
ØWh (mm)	86	86	116	150	150	150
Approx. Weight (Kg)	1.5	1.8	3.1	6.3	6.1	8.3

1500#	15mm (1/2")	20mm (3/4")	25mm (1")	32mm (1-1/4")	40mm (1-1/2")	50mm (2")
F/F (mm)	80	100	120	120	130	140
ØP (mm)	9.5	12.7	15.9	22.2	27	34.9
H OPEN (mm)	151	178	227	227	256	303
H CLOSE (mm)	138	162	207	207	224	263
ØWh (mm)	86	116	150	150	150	225
Approx. Weight (Kg)	1.7	2.9	6.1	5.9	8.5	13.9

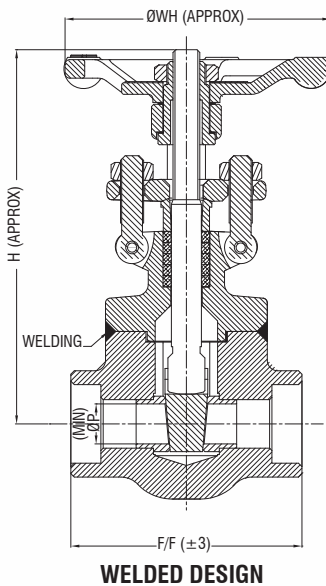
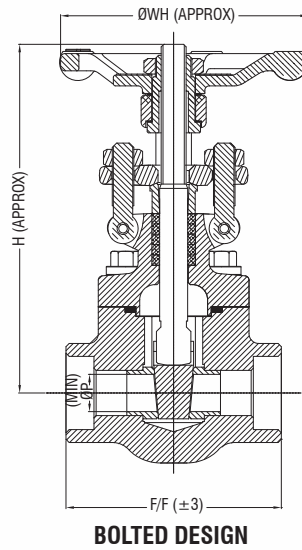

2500#	15mm (1/2")	20mm (3/4")	25mm (1")	32mm (1-1/4")	40mm (1-1/2")	50mm (2")
F/F (mm)	100	120	130	140	140	-
ØP (mm)	7	12.5	15.5	21.5	26.5	-
H OPEN (mm)	187	224	261	318	318	-
H CLOSE (mm)	174	204	239	290	290	-
ØWh (mm)	116	150	150	225	225	-
Approx. Weight (Kg)	2.9	6.1	8.5	14	13.9	-

150#	15mm (1/2")	20mm (3/4")	25mm (1")	32mm (1-1/4")	40mm (1-1/2")	50mm (2")
F/F (mm)	108	117	127	140	165	178
ØP (mm)	9.5	12.7	17.5	23.8	28.6	36.5
ØA (mm)	15.7	20.9	26.7	35	40.9	52.5
ØF (mm)	90	100	110	115	125	150
FT (mm)	9.6	11.2	12.7	14.3	15.9	17.5
ØRF (mm)	34.9	42.9	50.8	63.5	73	92.1
RFH (mm)	1.7	1.7	1.7	1.7	1.7	1.7
PCD (mm)	60.3	69.9	79.4	88.9	98.4	120.7
Approx. Weight (Kg)	2.3	2.9	4.6	8.6	8.5	14

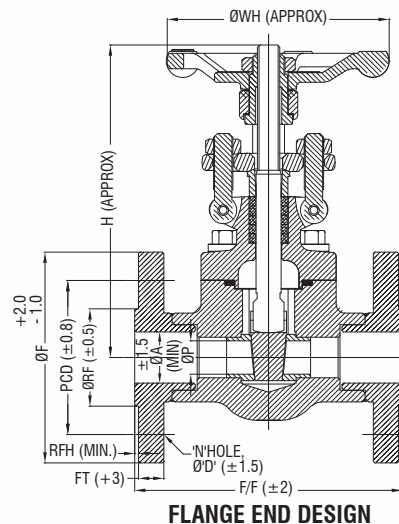

\*Flange End Valve also Available in 300#, 600# & Above Class on Request.