

Saunders[®]
the science inside 

brands you trust.



Industrial Diaphragm Valves

CRANE[®]

ChemPharma Flow Solutions

www.cranechempharma.com

Contents

Page Content	Page No.
Saunders – A Continuing Story of Success	2
Saunders Diaphragm Valve – Features	3
Valves for Corrosive and Abrasive Applications	4
Saunders Diaphragm Valve Range	5
Saunders A Type Diaphragm Valves	
Valve Benefits for Corrosive & Abrasive Applications	6/7
Materials of Construction – Valve Bodies	8/9
Materials of Construction – Diaphragms	10/11
Diaphragm Materials and Ratings	12/13
Dimensions, Weights and Standards	14/15
Flow Coefficients – Cv and Kv	16/17
Large Valve Sizes DN400, DN450 and DN500	18
Manual Bonnet Options	19
Saunders WFB Type Valves	
WFB Valve Materials of Construction	20
WFB Models and Testing Approvals	21
Saunders KB Type Diaphragm Valves	
Features and Benefits	22/23
Materials of Construction	24
Valve Ratings, Diaphragm Materials	24
Endurance Bonnet	25
Flow Coefficients – Cv and Kv	26
Valve Dimensions & Weights	27
KB Valve Performance	28
Manual Bonnet Options	29
Saunders Pneumatic Valve Actuation	
EC & SSC Actuators	30
ECX Actuators	31
EV and ESM Actuators	32
Valve Throttling and Control	33
EC Materials of Construction	34
SSC Materials of Construction	35
ECX Materials of Construction	36
ESM Materials of Construction	37
EV Materials of Construction	38
EC, SSC & ECX Actuator Dimensions	39
ESM & EV Actuator Dimensions	40
Typical Applications	
Abrasive, Corrosive, Industrial, Aseptic	41
Accessories	
Valve Actuator Accessories	42/43
Engineering Software	
Engineering Selection Tools	44
Quality Assurance	
PED and CE Marking, Approvals	45
Ordering Information	
Valve Model Numbering System	46/49
Notes	50/51

Crane Process Flow Technologies Ltd is an international leader in the design, development and manufacture of diaphragm valves and control products under the Saunders brand. Part of Crane Co, a global manufacturing and Sales Organisation, Crane Process Flow Technologies Ltd has a strong worldwide presence via dedicated Sales companies and distribution partners.

P K Saunders invented the original diaphragm valve in 1928. Since then, we have developed our range through innovative designs and by using the latest materials technology. As a result, Saunders diaphragm valves have gained an excellent reputation for versatility and reliability establishing a presence in every process industry sector. Today there are millions of Saunders diaphragm valves installed on process plants around the world.

There is one reason above all others for this success: ours are the valves that engineers know they can trust. We have set the industry standard for dependable, consistent operation year after year under even the most adverse conditions. In choosing Saunders, customers know they are assured of many years of trouble-free and reliable products.

Customers also know they can depend on us for after sales service, support and technical advice from one of our many locally based Crane sales companies and distribution partners.



The Original and the Best

Saunders diaphragm valve features and benefits for corrosive and abrasive applications with 100% leaktight closure operation

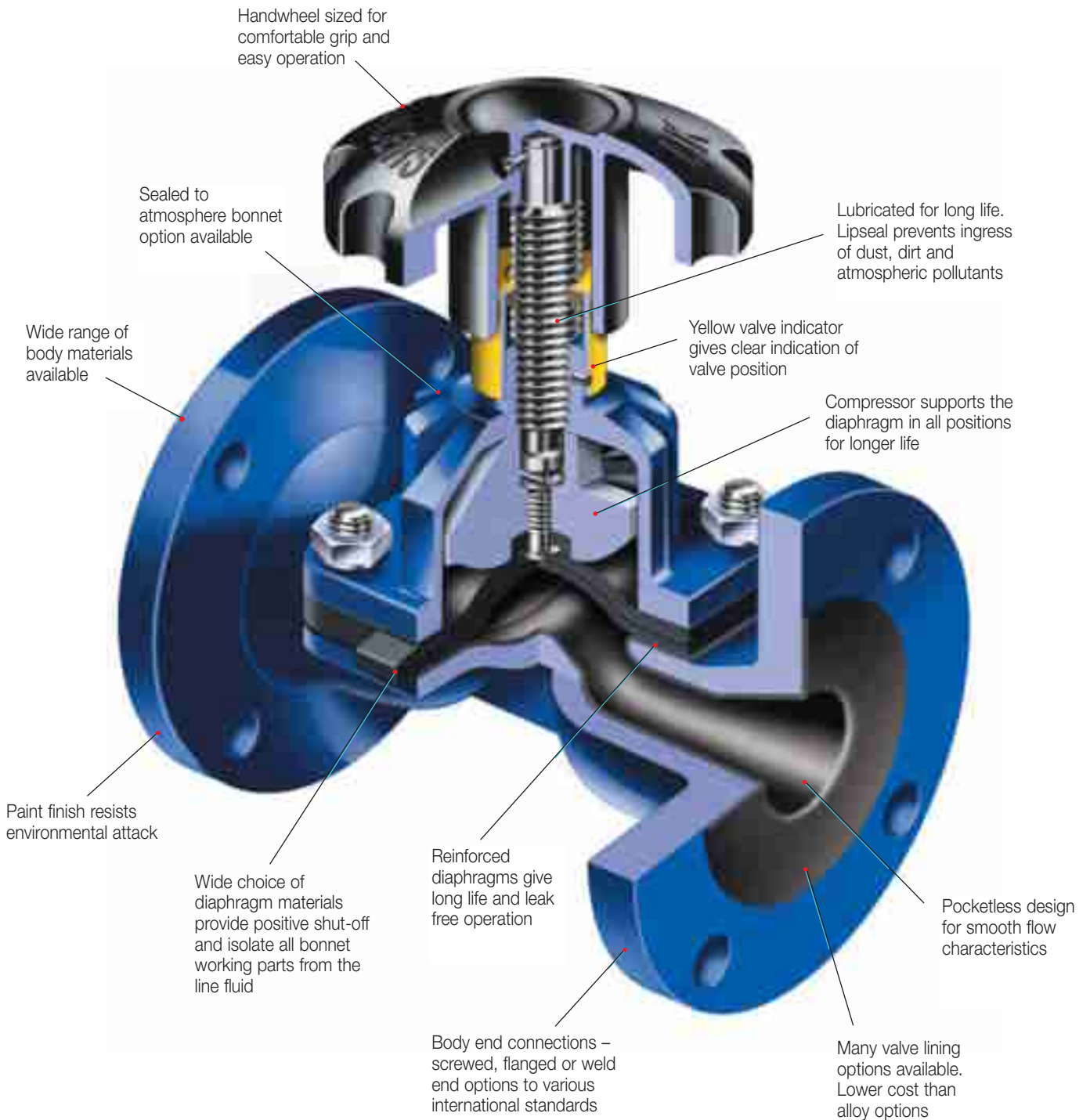

Saunders Diaphragm Valve Range

Valves for Corrosive and Abrasive Applications

We at Crane Process Flow Technologies Ltd have in our Saunders portfolio a comprehensive range of diaphragm valves for industry. They encompass the full spectrum of corrosive and abrasive applications that require reliable leak free valve operation.

Easily maintained to ensure many years of trouble free operation, the Saunders valve has become the standard valve used in many industries such as chemical production, mining, water treatment, fertiliser production and marine to name just a few.

Comparison of different valve types against industrial process requirements

Valve/Service features	Diaphragm	Ball	Butterfly	Globe	Gate	Lubricated Plug
Ability of leak tight shut-off against gases, liquids and solids	★★★★★	★	★	★	★	★
Resistance to abrasion and erosion	★★★★★	★	★	★	★	★
Wide choice of materials to match service	★★★★★	★	★	★	★	★
Non-turbulent flow path	★★★★★	★	★	★	★	★
Low fluid friction loss	★★★★★	★	★	★	★	★
Weight/size ratio	★★★★★	★	★	★	★	★
Resistance to corrosion	★★★★★	★	★	★	★	★
Compact overall height	★★★★★	★	★	★	★	★
Pressure range	★★★★★	★	★	★	★	★
Vacuum capability	★★★★★	★	★	★	★	★
Maintenance – in line servicing, low cost spares	★★★★★	★	★	★	★	★
High purity	★★★★★	★	★	★	★	★
Control applications	★★★★★	★	★	★	★	★
On/off applications	★★★★★	★	★	★	★	★
Temperature range	★★★★★	★	★	★	★	★

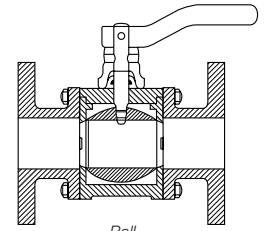

Ball

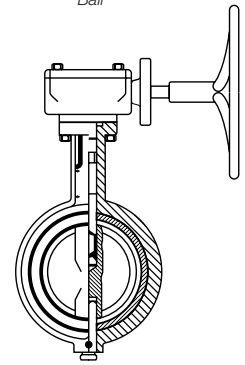

Butterfly

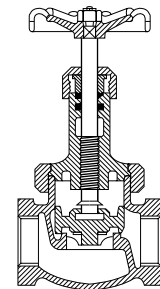

Globe

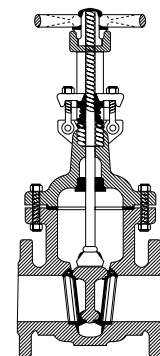

Gate

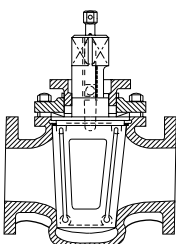

Plug

★★★★★ Five stars – exceptional
★ One star – poor

Saunders Diaphragm Valve Range

Valves for Corrosive and Abrasive Applications

A Type screwed

Weir type valve in SG iron, gunmetal and stainless steel.
DN8 to DN50



WFB

A specialised range of weir type diaphragm valves for marine and firefighting applications. Used primarily as water hydrant valves because of 100% reliability in adverse conditions.

DN40 and DN65



A Type flanged

Weir type flanged valve in cast iron, SG iron, cast steel, gunmetal and stainless steel. Can also be provided with various body linings and diaphragms to suit most industrial duties including corrosive and abrasive applications.

DN15 to DN350



AFP valve

Weir type diaphragm valve in stainless steel for the biopharm and chemicals markets.

DN8 to DN150



KB Type screwed

Straight through bore screwed valve in cast iron, gunmetal and stainless steel.

DN15 to DN50



KB Straight through valve

Diaphragm valve with a full bore opening to ensure maximum flow when handling viscous or abrasive fluids. Also available with various diaphragm and lining options.

DN15 to DN350

Saunders A Type Diaphragm Valves

Valve Benefits for Corrosive and Abrasive Applications

Our Saunders A Type diaphragm valves have been developed to handle a wider range of fluids and gases than any other valve type. A wide choice is available for materials, methods of operation and body end connections – to satisfy the needs of most corrosive and abrasive applications.

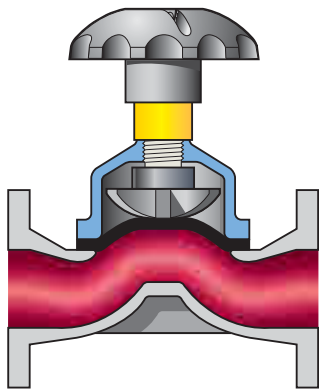

Valve flow

Pocketless design for contamination free performance and smooth flow characteristics. Linear operation ensures valve does not induce damaging pressure surges or static charges.

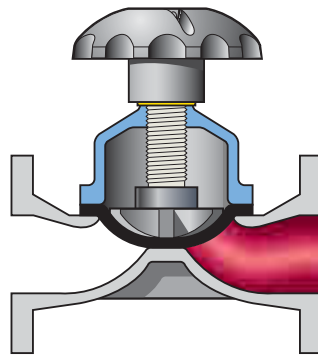

Ease of maintenance

Three part design allows maintenance and actuator retrofitting without removing the valve from the pipeline. Overall this results in lower cost of ownership compared to other valve types.



On pressure and vacuum, Saunders diaphragm valves operate and close 100% leaktight even after thousands of operations. This feature reduces processing and handling costs, by eliminating emissions normally associated with conventional valve designs.

All working parts of the valves are isolated from the line media and positive closure is obtained even on frequent cycling or with entrained particulates in the line unlike quarter turn ball and butterfly valves. Throttling and control characteristics are enhanced by a streamlined flow path that is cavity free and provides excellent flow control capabilities.

Extended life, reliability, safety and ease of use, combined with an essentially simple design, results in low maintenance for minimum running costs.

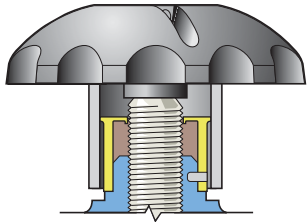

Lubrication

Bonnet assembly lubricated for long life. Needs no additional grease. The indicator lip seal stops the ingress of dust, dirt and atmospheric contaminates.

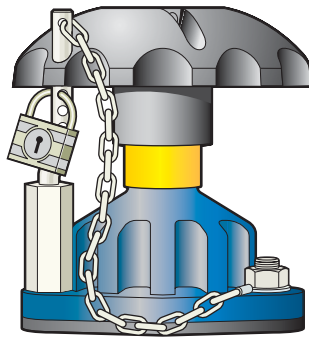

Padlock bonnet

Restricted valve operation can be achieved by utilising the padlocking bonnet option.

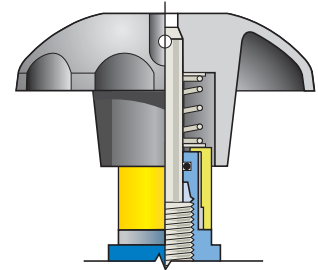

Sealed bonnet

In cases where hazardous liquids or gases are being handled and where additional safety features are considered to be necessary.

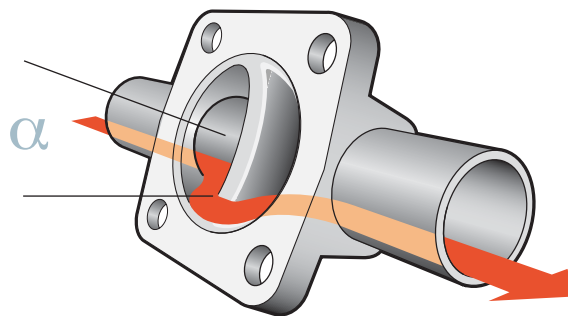

Valve usable in any position

The Saunders valve can be installed in any position without affecting its operation. However, we recommend 6x pipe diameter from bend or pump.

Valve set for self draining

The Saunders valve can be installed to assist self-draining if required. Please consult us for drainage angle advice.

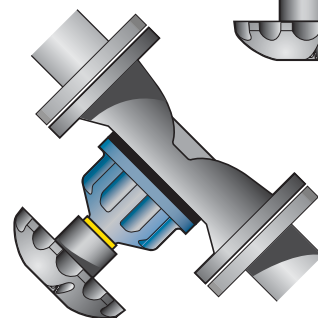
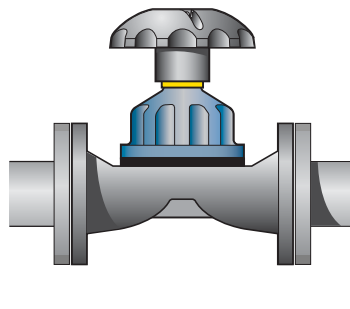
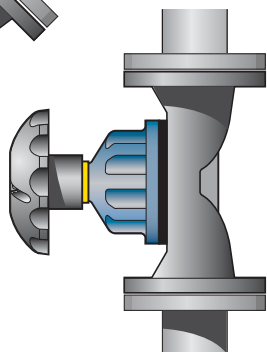
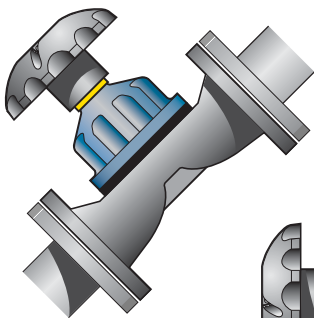
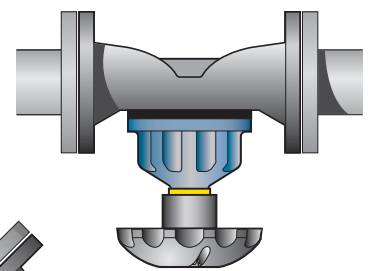

Saunders A Type Diaphragm Valves

Materials of Construction – Valve Bodies

Standard Unlined Body Material

CAST IRON			
BS EN 1561	GJL-250	Flanged	DN15–DN500
SG IRON			
BS EN 1563	GJS-450-10	Screwed	DN15–DN50
BS EN 1563	GJS-400-18	Flanged	DN15–DN150
	GJS-400-18-LT		
CAST STEEL			
	ASTM A216 WCB	Flanged	DN15–DN100
BRONZE			
BS EN 1982	CC491K-GS	Screwed	DN15–DN50
BS EN 1982	CC492K-GS	Flanged	DN15–DN100
STAINLESS STEEL			
BS 3100	316C16	Screwed	DN15–DN50
BS 3100	316C16	Flanged	DN15–DN150

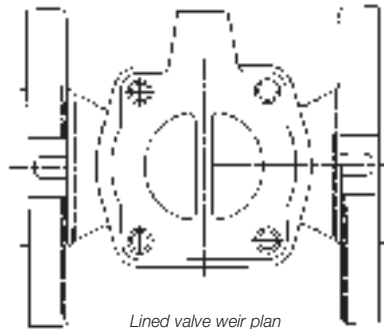
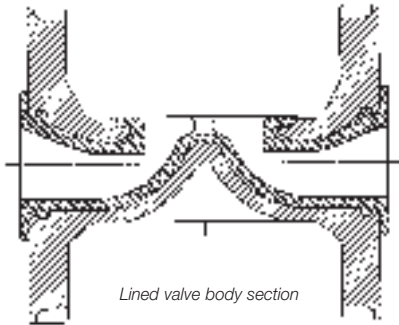

Plastic lined body features

- ◆ SG iron body – high mechanical strength
- ◆ SG iron body – mechanically supports plastic lining
- ◆ Lining protected from ultraviolet (UV)
- ◆ Injection gate to side of weir flange means:–
- Smooth weir for diaphragm sealing and zero leakage
- Lining lock-on weir flange and in-bore inlet
- Lining thickness range 3–5mm (DN20–DN150)

Rubber lined body data

- ◆ Soft rubber linings
- Butyl (Isobutylene isoprene), 60–66° IRHD
- ◆ Hard ebonite rubber HRL, 75–85° Shore D
- ◆ Lining thickness range 2–4.5mm (DN20–DN350)

Valve body lining – production tests

All Saunders lined valves have each body individually tested for lining integrity.

- ◆ Glass lining – Spark test 10kV ac
- ◆ Rubber, Butyl – Spark test 14kV ac/dc
- ◆ Rubber, HRL – Spark test 17kV ac/dc
- ◆ Plastic lined – Spark test 20kV ac/dc

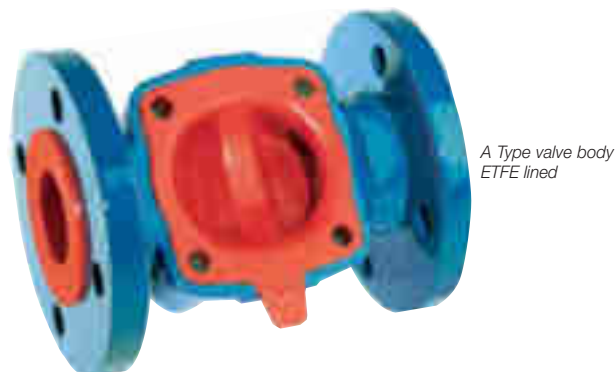

Saunders Environmental Protection

Saunders environmental protective coating has been developed specifically to provide unrivalled corrosive resistance in the industrial processing industry, the new protective coating utilises Du Pont's Tefzel™ (Ethylenetetrafluoroethylene) material.

The green Tefzel™ coating is applied before the injection moulding of the Perfluoroalkoxy (PFA) or Ethylenetetrafluoroethylene (ETFE) lining, using an electrostatic powder coating method. By coating the valve body, bonnet and hand wheel, both internal and external corrosive protection is maximised providing peace of mind in extreme corrosive material processing applications.

Available in DN 20-100 with a PFA lining and DN 20 – 150 in the ETFE lined option.



Valve Body Linings for Saunders Valves

◆ Hard Rubber – NR/HRL

Used for salts in water, dilute mineral acids, chlorine water, de-ionised water, plating solutions and potable water.

◆ Soft Butyl Rubber – IIR/BL

Good for corrosive and abrasive slurries, mineral acids and acidic slurries.

◆ Glass

Used in multi-process chemical plants on acids and solvents.

◆ Polypropylene – PP

Main applications include mineral acids, salts in water, water and effluent treatment chemicals.

◆ Ethylene tetrafluoroethylene – ETFE

Suitable for strong acids, salts in water at higher temperatures, solvents at medium temperature.

◆ Perfluoroalkoxy – PFA

Most suitable for concentrated mineral acids at high temperature, aromatic, aliphatic and chlorinated solvents.

◆ Polytetrafluoroethylene – PTFE

Most suitable for concentrated mineral acids at high temperature, aromatic, aliphatic and chlorinated solvents.

◆ Soft Natural Rubber - AA/SRL

High abrasion resistance. Suitable for use on powders, abrasive slurries, clays, coal dust, dry fertilizer, gypsum.

◆ Neoprene – NRL

Particularly suitable for animal, vegetable, fatty oils and greases. Abrasion resistance over wide pH range –used for aggressive slurries.

Valve Body Lining Materials – Visual Process Resistance Guide

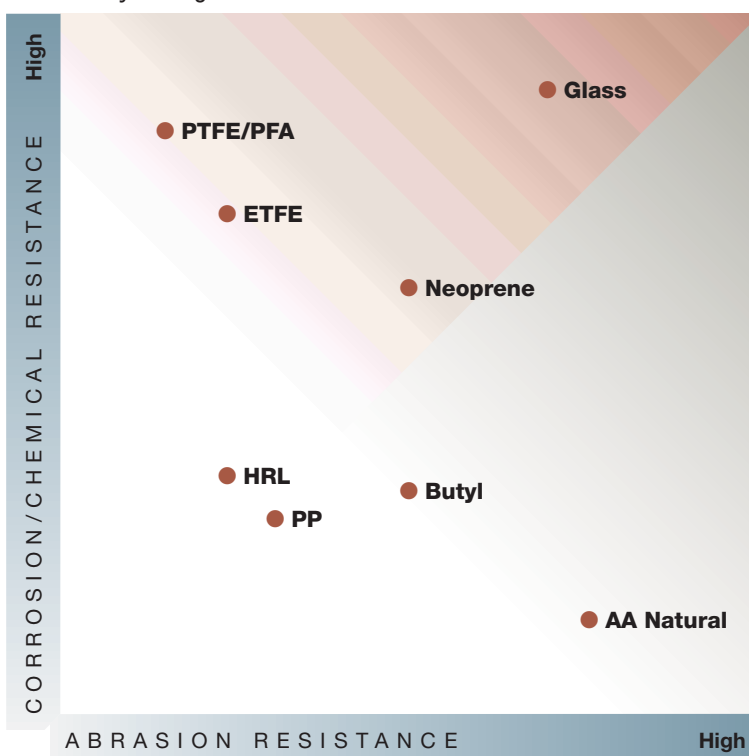

Saunders A Type Diaphragm Valves

Materials of Construction – Diaphragms

We at Crane Process Flow Technologies are proud of our core competence, the in-house manufacture of Saunders diaphragms for use within our valve range. Many years of experience has resulted in a range of diaphragms, which handle a wide variety of fluids with total security. The guaranteed high performance of Saunders diaphragms results from stringent quality control and continuous development.



Key Considerations

- ◆ High flex performance
- ◆ Good compression set properties
- ◆ Chemical resistance
- ◆ Abrasion resistance
- ◆ Anti-aging
- ◆ Approvals, traceability

Diaphragm Construction

Rubber Diaphragms

The polymer material is bonded with a high strength woven reinforcement to ensure maximum strength and durability.

- ◆ Constructed with multi-layers of rubber and nylon reinforcement
- ◆ Studs are attached with bonding adhesive and mechanical anchorage
- ◆ Rib on face for weir flange and across weir for leak tight sealing and lower closure torque
- ◆ Compressor support in both the open and closed positions for extended life

PTFE Diaphragms

A two piece construction PTFE face with a rubber backing diaphragm to increase pressure rating and durability. These diaphragms have a bayonet fitting to ensure reliable installation, reduced point loading and ensure maximum life. The 214K is three piece specially reinforced for chlorine service.



PTFE diaphragm bayonet fixing



Rubber diaphragm screw fixing

Saunders A Type Diaphragm Valves

Diaphragm Materials of Construction

Grade	Elastomer type	General service and approvals
C	Butadiene Acrylonitrile, sulphur cured, black reinforced	Lubricating oil, cutting oils, paraffin, animal and vegetable oils, aviation kerosene
CV	Butadiene Acrylonitrile, sulphur cured, black reinforced	Vacuum where oils are present, compressed air, liquid petroleum gas (LPG)
HT	Polychloroprene, sulphur cured, black reinforced	Abrasive slurries containing hydrocarbons
Q	Natural rubber polyisoprene/SBR, sulphur cured, black reinforced	Salts in water, dilute acids and alkalis, abrasives
226	Fluoroelastomer, amine cured, black reinforced	Concentrated acids, aromatic solvents, chlorine, ozone, chlorinated solvents, unleaded petroleum
237	Chlorosulphonated polyethylene metal oxide cured, black reinforced	Strong acids, sodium hypochlorite, chlorine gas
286	Chlorosulphonated polyethylene metal oxide cured, black reinforced Kevlar fabric reinforced	Fire mains isolation in WFB valve
300	Isobutylene Isoprene, resin cured black reinforced	Salts in water, dilute acids and alkalis, drinking water, Food & Drug Administration (FDA), United States Pharmacopeia (USP), Water Regulations Advisory Scheme (WRAS)
425	Ethylene propylene (EPM) organic peroxide cured, black reinforced	Salts in water, acids and alkalis, ozone, intermittent steam, drinking water, FDA, USP, WRAS
425V	Ethylene propylene (EPM) organic peroxide cured, black reinforced	Vacuum where acid, alkali, water vapours are present, FDA, USP, WRAS
214/226	Virgin PTFE/Fluoroelastomer – two piece	Strong acids, solvents, chlorine, bromine at higher temperatures
214/300	Virgin PTFE/Isobutylene isoprene – two piece	Strong acids, alkalis and salts in water at high temperature. Constant steam, water for injection (WFI), biopharmaceuticals, FDA USP, WRAS
214/425	Virgin PTFE/Ethylene propylene – two piece	Strong acids, alkalis and salts in water at high temperature. Constant steam, water for injection (WFI), biopharmaceuticals, FDA, USP, WRAS
214S/425	Virgin PTFE/PPVE/Ethylene propylene – two piece	Strong acids, alkalis and salts in water at high temperature. Constant and intermittent steam, WFI, biopharmaceuticals, FDA, USP, WRAS
214K/425	Virgin PTFE/PVDF/Ethylene propylene – three piece	Chlorine, bromine gas and chlorinated solvents



Standard

- ◆ Rubber diaphragms have a brass stud
- ◆ Diaphragms suitable for vacuum duties (eg. CV) have steel stud
- ◆ PTFE diaphragms are fitted with stainless steel bayonet

Saunders Diaphragms are provided with:–

- ◆ Full traceability of manufacture to EN10204 3.1b (was DIN 50049 3.1b)
- ◆ Coding tag for both material and batch number for easy identification
- ◆ Saunders name to confirm genuine manufacture and maximum reliability

Saunders A Type Diaphragm Valves

Diaphragm Materials

Diaphragm Materials – Visual Process Resistance Guide

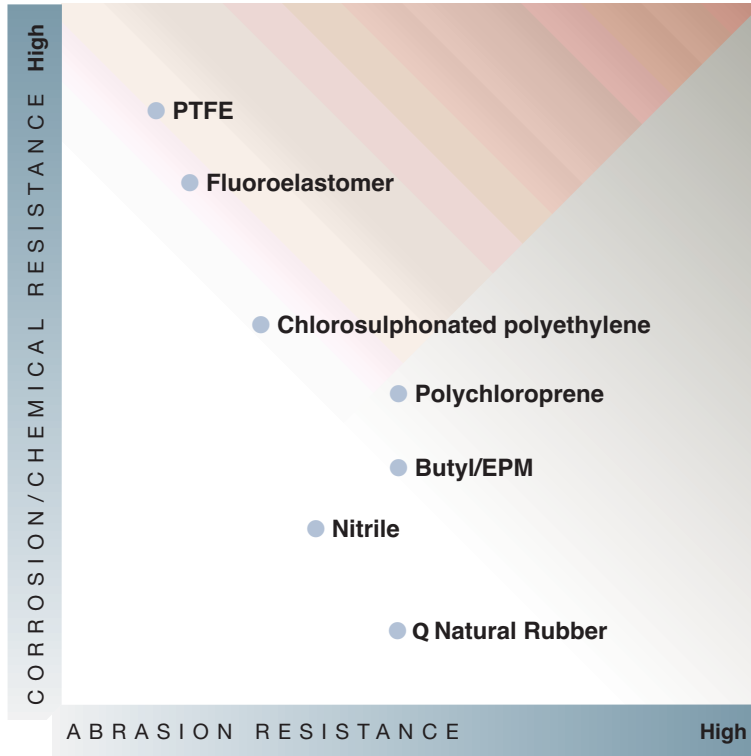

Material	Grade
PTFE	214/214K
Fluoroelastomer	226
Chlorosulphonated polyethylene	237
Polychloroprene	HT
Nitrile	C, CV
Butyl	300, 300V
EPM	425, 425V
Natural Rubber	Q

Maximum working pressure (bar) – A Type valves

As with all valves, the application and environment have a major bearing on actual valve operating limits, but the following can be used as a guide to the maximum operational limits.

Size DN	8	10	15	20	25	32	40	50	65	80	100	125	150	200	250	300	350
Non-rising handwheel														6	5	4	3.5
Rising handwheel	16	16	16	16	16	16	16	16	10	10	10	10	10				
WFB and tank cleaning							15	15									

Size DN	8	10	15	20	25	32	40	50	65	80	100	125	150	200	250
Non-rising handwheel														6	5
Rising Handwheel	10	10	10	10	10	10	10	10	10	10	10	10	7		

Diaphragm Performance

Temperature and Pressure Relationship

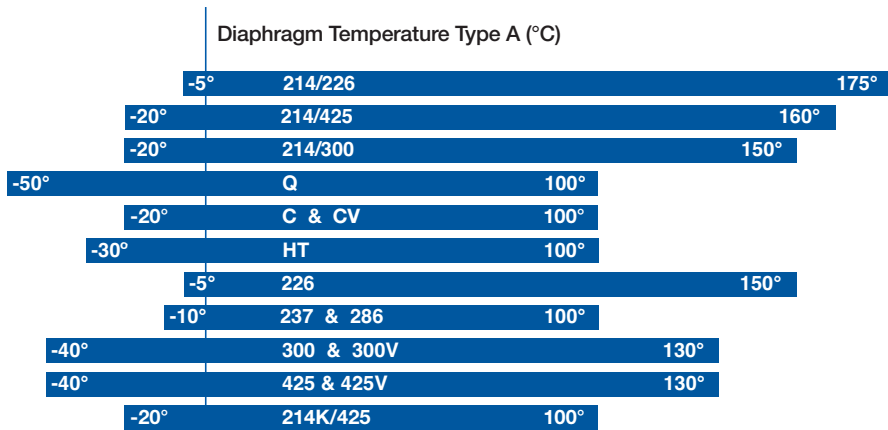

A Type Valve Body (SG Iron & Cast Iron) Temperature/Pressure Relationship

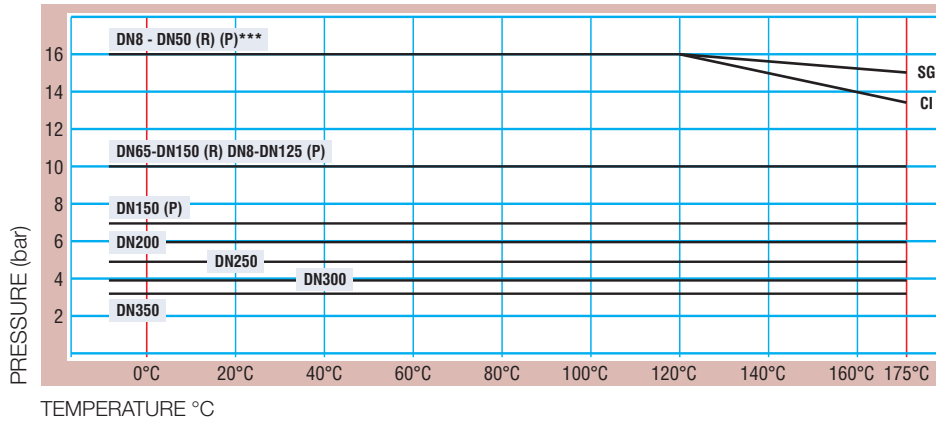

A Type Valve Body (Carbon Steel, St. Steel & Copper Alloys) Temperature/Pressure Relationship

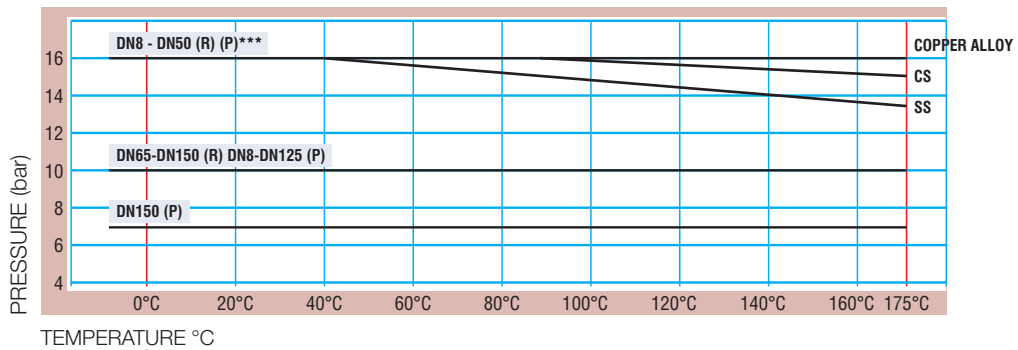

Body Temperature Limit (°C)**		
-10°	HARD RUBBER LINED	85°
-10°	POLYPROPYLENE LINED (P.P.)	85°*
-10°	BUTYL RUBBER LINED	110°
-10°	ETHYLENE TETRAFLUOROETHYLENE (ETFE)	150°
-10°	CAST IRON: UNLINED, GLASS LINED & PTFE LINED	175°
-10°	SG IRON: UNLINED AND PFA LINED	175°
-30°	OTHER METALS: CARBON STEEL, STAINLESS STEEL, COPPER ALLOYS	175°

Temperature bands for diaphragms are shown as a guide only. Many aspects of service conditions will determine the highest working temperature. For example, 325 diaphragms have given excellent performance under certain conditions up to 150°C.

In certain applications the following temperature ratings apply:
SG: -20°C, SS: -30°C, GM: -30°C.

* Depends on body substrate material.

** When lined body is cast steel, minimum temperature is -30°C.

When SG Grade EN-GJS-400-18-LT is used, minimum temperature is -20°C.

*** 214S manual operation only.

Saunders Diaphragm Valves

Dimensions, Weights and Standards

Valve Standards

As well as being in overall lengths to EN 558-1 Series 1 and Series 7 and MSS SP88, Saunders valves are manufactured to the following standards:

Flanges	
BRITISH	BS 10 tables D and E BS 4504 tables PN10/16 BS 1560 Class 150
EUROPEAN	EN 1092-1 PN10/16 EN 1092-2 PN10/16
AMERICAN	ASME/ANSI B16.1 Class 125 ASME/ANSI B16.5 Class 150 and B16.24 Class 150
JAPANESE	JIS B 2212

Female screwed pipe connections	
BRITISH	BS 21 taper BS 21 parallel
AMERICAN	API 5B
GERMAN	DIN 259
INTERNATIONAL	ISO 7/1 taper ISO 7/1 parallel



Saunders A Type Diaphragm Valves

Dimensions and Weights

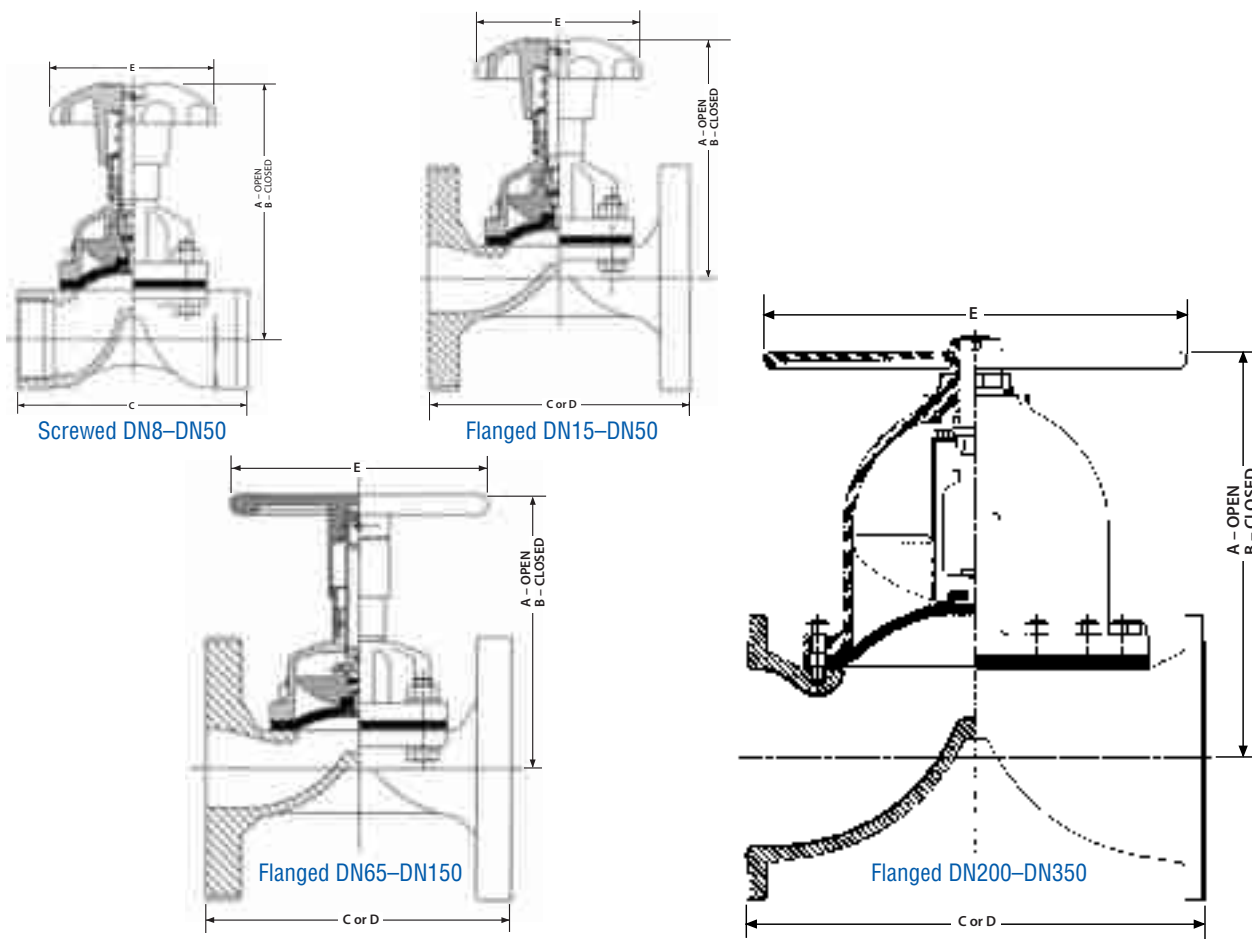

Valve Diameter (DN)

		50	65	80	100	125	150	175	200	225	250	280	300	350	400	450	500	600	660
Screwed	A	54	67	90	94	119	154	164	188	-	-	-	-	-	-	-	-	-	-
	B	52	61	84	88	108	142	148	164	-	-	-	-	-	-	-	-	-	-
	C	49	49	63.5	83	111	125	145	168	-	-	-	-	-	-	-	-	-	-
	Weight	0.11	0.15	0.45	0.90	1.13	1.80	2.70	5.00	-	-	-	-	-	-	-	-	-	-
Flanged	A	-	-	100	91	108	143	157	175	226	243	308	388	442	495	581	679	660	-
	B	-	-	93	85	98	131	141	152	194	208	262	322	367	-	-	-	-	-
	C	-	-	108	117	127	146	159	190	216	254	305	356	406	521	635	749	749	-
	D	-	-	130	150	160	180	200	230	290	310	350	400	480	600	730	850	980	-
Weight	-	-	1.80	1.80	2.70	4.00	4.90	7.70	14.0	19.0	31.7	48.0	62.1	152	270	360	506	-	
Flanged Rubber Lined	A	-	-	-	97	111	146	160	177	229	246	311	391	445	498	585	683	664	-
	B	-	-	-	91	101	134	144	154	197	212	265	325	370	-	-	-	-	-
	C	-	-	-	121	131	150	163	194	220	258	309	362	412	527	641	755	755	-
	D	-	-	-	150	160	180	200	230	290	310	350	400	480	600	730	850	980	-
Weight	-	-	-	2.70	3.10	4.50	5.40	8.20	15.0	20.4	33.1	49.2	63.0	154	273	365	512	-	
Flanged Glass Lined	A	-	-	101	92	109	144	158	176	227	244	309	389	443	496	582	-	-	-
	B	-	-	94	86	99	132	142	153	195	210	263	323	368	-	-	-	-	-
	C	-	-	110	119	129	148	161	192	218	256	307	358	408	523	637	-	-	-
	D	-	-	130	150	160	180	200	230	290	310	350	400	480	600	730	-	-	-
Weight	-	-	1.80	1.80	3.10	4.50	5.40	8.20	14.5	19.5	32.2	48.5	62.6	153	272	-	-	-	
Flanged Plastic Lined	A	-	-	-	97	112	-	162	176	-	246	314	-	450	-	-	-	-	-
	B	-	-	-	91	102	-	145	155	-	211	267	-	374	-	-	-	-	-
	C	-	-	-	123	133	-	165	196	-	260	311	-	412	-	-	-	-	-
	D	-	-	-	150	160	-	200	230	-	310	350	-	480	-	-	-	-	-
Weight	-	-	-	2.70	3.10	-	5.40	8.20	-	20.4	33.1	-	63.0	-	-	-	-	-	
E	38	50	62	62	80	120	120	120	170	230	280	280	368	482	584	699	699	-	-

Weights in kg. **C** valve length = EN 558-1 Series 7 (ex BS 5156). **D** valve length = EN 558-1 Series 1 (ex DIN 3202 Series F1).

Saunders A Type Valve

Flow Co-efficient of Valve Range Cv (Kv)

DN	BODY MATERIAL / LINING							
	Cast iron		Rubber Lined		Glass		Plastic Lined	
	Cv	Kv	Cv	Kv	Cv	Kv	Cv	Kv
% Open								
100	5.50	4.71	--	--	6.00	5.14	--	--
90	5.28	4.53	--	--	5.75	4.93	--	--
80	5.06	4.33	--	--	5.51	4.72	--	--
70	4.83	4.14	--	--	5.27	4.52	--	--
60	4.61	3.95	--	--	5.03	4.31	--	--
50	3.84	3.29	--	--	4.19	3.59	--	--
40	3.08	2.62	--	--	3.35	2.87	--	--
30	2.30	1.97	--	--	2.51	2.15	--	--
20	1.54	1.32	--	--	1.67	1.43	--	--
10	0.77	0.66	--	--	0.83	0.71	--	--
0	0	0	--	--	0	0	--	--

DN	BODY MATERIAL / LINING							
	Cast iron		Rubber Lined		Glass		Plastic Lined	
	Cv	Kv	Cv	Kv	Cv	Kv	Cv	Kv
% Open								
100	11.50	9.86	9.20	7.89	12.00	10.29	6.50	5.59
90	11.03	9.45	9.00	7.71	11.51	9.87	6.24	5.35
80	10.57	9.06	8.80	7.54	11.03	9.45	5.98	5.13
70	10.12	8.67	8.40	7.20	10.55	9.04	5.72	4.90
60	9.66	8.28	7.70	6.60	10.07	8.63	5.45	4.67
50	8.05	6.90	6.70	5.74	8.39	7.19	4.54	3.89
40	6.43	5.51	5.50	4.71	6.71	5.75	3.63	3.11
30	4.83	4.14	4.10	3.51	5.03	4.31	2.72	2.33
20	3.21	2.75	2.50	2.14	3.35	2.87	1.81	1.55
10	1.60	1.37	1.00	0.86	1.67	1.43	0.90	0.77
0	0	0	0	0	0	0	0	0

DN	BODY MATERIAL / LINING							
	Cast iron		Rubber Lined		Glass		Plastic Lined	
	Cv	Kv	Cv	Kv	Cv	Kv	Cv	Kv
% Open								
100	17.60	15.09	14.00	12.00	18.00	15.43	11.19	9.60
90	16.29	13.96	13.70	11.74	17.28	14.81	10.75	9.21
80	16.19	13.88	13.40	11.49	16.56	14.19	10.30	8.83
70	15.48	13.26	12.70	10.89	15.83	13.57	9.85	8.42
60	14.78	12.67	11.60	9.94	15.11	12.95	9.40	8.06
50	12.32	10.56	10.20	8.74	12.59	10.79	7.83	6.71
40	9.85	8.44	8.40	7.20	10.07	8.63	6.27	5.37
30	7.39	6.33	6.30	5.40	7.55	6.47	4.70	4.02
20	4.92	4.22	3.80	3.25	5.03	4.31	3.13	2.68
10	2.46	2.11	1.50	1.29	2.51	2.15	1.56	1.34
0	0	0	0	0	0	0	0	0

DN	BODY MATERIAL / LINING							
	Cast iron		Rubber Lined		Glass		Plastic Lined	
	Cv	Kv	Cv	Kv	Cv	Kv	Cv	Kv
% Open								
100	27.50	23.57	22.00	18.86	28.00	24.00	16.70	14.31
90	26.39	22.61	21.12	18.10	26.88	23.04	16.03	13.74
80	25.29	21.68	20.24	17.35	25.75	22.07	15.36	13.17
70	24.20	20.74	19.35	16.59	24.64	21.11	14.69	12.59
60	23.09	19.79	18.47	15.83	23.51	20.15	14.02	12.02
50	19.25	16.50	15.39	13.19	19.60	16.80	11.69	10.02
40	15.39	13.19	12.32	10.57	15.67	13.43	9.35	8.01
30	11.54	9.89	9.23	7.91	11.75	10.07	7.01	6.01
20	7.69	6.59	6.16	5.28	7.83	6.71	4.67	4.00
10	3.84	3.29	3.08	2.62	3.91	3.35	2.33	1.98
0	0	0	0	0	0	0	0	0

DN	BODY MATERIAL / LINING							
	Cast iron		Rubber Lined		Glass		Plastic Lined	
	Cv	Kv	Cv	Kv	Cv	Kv	Cv	Kv
% Open								
100	43.00	36.86	35.00	30.00	45.00	38.57	31.00	26.57
90	41.28	35.40	34.00	29.14	43.20	37.03	29.76	25.51
80	39.56	33.91	33.6	28.80	41.39	35.48	28.51	24.43
70	37.84	32.43	32.00	27.43	39.59	33.93	27.28	23.38
60	36.11	30.95	29.00	24.86	37.79	32.41	26.03	22.32
50	30.10	25.81	26.00	22.28	31.50	27.00	21.69	18.59
40	24.07	20.63	21.00	18.00	25.19	21.59	17.35	14.87
30	18.05	15.47	16.00	13.68	18.89	16.19	13.01	11.15
20	12.03	10.31	9.5	8.14	12.59	10.79	8.67	7.43
10	6.01	5.15	3.9	3.34	6.29	5.39	4.33	3.71
0	0	0	0	0	0	0	0	0

DN	BODY MATERIAL / LINING							
	Cast iron		Rubber Lined		Glass		Plastic Lined	
	Cv	Kv	Cv	Kv	Cv	Kv	Cv	Kv
% Open								
100	80.00	68.61	64.00	54.89	88.00	75.47	59.00	50.60
90	76.80	65.86	63.00	54.03	84.48	72.45	56.00	48.00
80	73.59	63.11	61.00	52.31	80.96	69.43	54.00	46.29
70	70.40	60.37	58.00	49.71	77.43	66.40	52.00	44.57
60	67.19	57.62	53.00	45.43	73.91	63.38	50.00	42.86
50	56.00	48.03	47.00	40.29	61.69	52.82	41.00	35.14
40	44.79	38.39	38.00	32.57	49.28	42.24	33.00	28.28
30	33.59	28.79	29.00	24.86	36.95	31.67	25.00	21.43
20	22.39	19.19	17.00	14.57	24.64	21.11	16.00	13.71
10	11.19	9.60	7.00	6.00	12.32	10.56	8.00	6.86
0	0	0	0	0	0	0	0	0

DN	BODY MATERIAL / LINING							
	Cast iron		Rubber Lined		Glass		Plastic Lined	
	Cv	Kv	Cv	Kv	Cv	Kv	Cv	Kv
% Open								
100	127.00	108.80	102.00	87.40	132.00	113.10	83.00	71.10
90	121.00	103.70	97.90	83.90	126.00	108.00	79.70	68.30
80	116.00	99.40	93.80	80.40	121.00	103.70	76.40	65.40
70	111.00	95.10	89.80	76.90	116.00	99.40	73.00	62.60
60	106.00	90.90	85.70	73.40	110.00	94.30	69.70	59.80
50	88.90	76.20	71.40	61.20	92.40	79.20	58.10	49.80
40	71.12	60.90	57.10	48.90	73.90	63.40	46.50	39.80
30	53.33	45.70	42.80	36.70	55.40	47.50	34.90	29.90
20	35.56	30.50	28.60	24.50	37.00	31.70	23.20	19.90
10	17.78	15.20	14.30	12.20	18.50	15.84	11.60	9.90
0	0	0	0	0	0	0	0	0

DN	BODY MATERIAL / LINING							
	Cast iron		Rubber Lined		Glass		Plastic Lined	
	Cv	Kv	Cv	Kv	Cv	Kv	Cv	Kv
% Open								
100	185.00	158.60	148.00	126.90	186.00	159.40	148.00	126.90
90	177.00	151.70	145.00	124.30	178.00	152.60	142.00	121.70
80	170.00	145.70	142.00	121.70	171.00	146.60	136.00	116.60
70	162.00	138.90	135.00	115.70	163.00	139.70	130.00	111.40
60	155.00	132.90	123.00	105.40	156.00	133.70	124.00	106.30
50	129.00	110.60	108.00	92.60	130.00	111.40	103.00	88.30
40	103.00	88.30	89.00	76.30	104.00	89.10	82.90	71.00
30	77.70	66.60	67.00	48.90	78.10	67.00	62.20	44.70
20	51.80	44.40	40.00	34.30	52.10	44.60	41.40	35.50
10	25.90	22.20	16.00	13.70	26.00	22.30	20.70	17.80
0	0	0	0	0	0	0	0	0

DN 100		BODY MATERIAL / LINING							
		Cast iron		Rubber Lined		Glass		Plastic Lined	
% Open		Cv	Kv	Cv	Kv	Cv	Kv	Cv	Kv
100		315	270	252	216	336	288	270	231
90		302	259	247	212	322	276	259	222
80		289	248	242	207	309	265	248	213
70		277	237	229	196	295	253	237	203
60		264	226	209	179	282	242	226	194
50		220	189	184	158	235	201	189	172
40		176	151	151	129	188	161	151	129
30		132	113	113	97	141	121	113	97
20		88.20	76	68	50	94.10	81	75.60	65
10		44.10	38	28	24	47.00	40	37.80	32.40
0		0	0	0	0	0	0	0	0

DN 125		BODY MATERIAL / LINING							
		Cast iron		Rubber Lined		Glass		Plastic Lined	
% Open		Cv	Kv	Cv	Kv	Cv	Kv	Cv	Kv
100		420	360	363	311	440	377	-	-
90		403	345	348	298	422	362	-	-
80		386	331	333	285	404	346	-	-
70		369	316	319	273	387	332	-	-
60		352	302	304	261	369	316	-	-
50		294	252	254	218	308	264	-	-
40		235	201	203	174	246	211	-	-
30		176	151	152	130	184	158	-	-
20		117	100	101	87	123	105	-	-
10		59	49	51	44	62	53	-	-
0		0	0	0	0	0	0	-	-

DN 150		BODY MATERIAL / LINING							
		Cast iron		Rubber Lined		Glass		Plastic Lined	
% Open		Cv	Kv	Cv	Kv	Cv	Kv	Cv	Kv
100		605	519	484	415	630	540	505	433
90		580	497	474	406	604	518	484	414
80		556	477	465	399	579	496	464	398
70		532	456	440	377	554	475	444	381
60		508	435	402	345	529	453	424	363
50		423	363	353	303	441	378	353	303
40		338	290	290	249	352	302	282	242
30		254	218	218	187	264	226	212	182
20		169	145	131	112	176	151	141	121
10		85	73	53	45	88	75	71	61
0		0	0	0	0	0	0	0	0

DN 200		BODY MATERIAL / LINING							
		Cast iron		Rubber Lined		Glass		Plastic Lined	
% Open		Cv	Kv	Cv	Kv	Cv	Kv	Cv	Kv
100		1300	1114	1309	1122	1320	1131	-	-
90		1248	1070	1256	1077	1267	1086	-	-
80		1196	1025	1204	1032	1214	1041	-	-
70		1144	981	1151	987	1161	995	-	-
60		1092	936	1099	942	1108	950	-	-
50		910	780	916	785	924	792	-	-
40		728	624	733	628	739	633	-	-
30		546	468	549	471	554	475	-	-
20		364	312	366	314	369	316	-	-
10		182	156	183	157	184	158	-	-
0		0	0	0	0	0	0	-	-

DN 250		BODY MATERIAL / LINING					
		Cast iron		Rubber Lined		Glass	
% Open		Cv	Kv	Cv	Kv	Cv	Kv
100		1980	1697	2000	1714	2100	1800
90		1900	1629	1920	1646	2015	1727
80		1821	1561	1840	1577	1932	1656
70		1742	1493	1760	1509	1848	1584
60		1663	1425	1679	1439	1763	1511
50		1386	1188	1400	1200	1470	1260
40		1108	950	1120	960	1176	1008
30		831	712	839	719	881	755
20		554	475	560	480	588	504
10		277	237	280	240	294	252
0		0	0	0	0	0	0

DN 300		BODY MATERIAL / LINING					
		Cast iron		Rubber Lined		Glass	
% Open		Cv	Kv	Cv	Kv	Cv	Kv
100		3700	3171	3750	3214	3880	3326
90		3552	3045	3600	3086	3724	3191
80		3404	2917	3450	2957	3569	3059
70		3256	2791	3300	2829	3414	2926
60		3107	2663	3149	2699	3259	2793
50		2590	2220	2625	2250	2716	2327
40		2072	1776	2100	1800	2172	1861
30		1553	1331	1574	1349	1629	1396
20		1036	888	1050	900	1086	931
10		518	444	525	450	543	465
0		0	0	0	0	0	0

DN 350		BODY MATERIAL / LINING					
		Cast iron		Rubber Lined		Glass	
% Open		Cv	Kv	Cv	Kv	Cv	Kv
100		3700	3171	3750	3214	3880	3326
90		3552	3045	3600	3086	3724	3191
80		3404	2917	3450	2957	3569	3059
70		3256	2791	3300	2829	3414	2926
60		3107	2663	3149	2699	3259	2793
50		2590	2220	2625	2250	2716	2327
40		2072	1776	2100	1800	2172	1861
30		1553	1331	1574	1349	1629	1396
20		1036	888	1050	900	1086	931
10		518	444	525	450	543	465
0		0	0	0	0	0	0

Note: Differing Cv & Kv rating can be derived, depending on the method used for testing. The tables above are based on British Standards 1042 and EN 60531/IEC 534.2.3 and show flow in US gallons per minute and cubic metres per hour.

Cv is flow in US gpm through valve at Δ P of 1 psi
Kv is flow in m³/hr through valve at Δ P of 1 bar

Saunders A Type Diaphragm Valves

Large Valve Sizes: DN400, DN450 & DN500

Some applications, for example, in the minerals processing and water treatment industries involving corrosive and abrasive slurries, have successfully utilised larger size Saunders diaphragm valves for many years. Double weir options are also available.

These double weir bodies utilise diaphragms and bonnets from the tried and tested DN300 and DN350 range of valves.

Valve sizes

DN400 fitted with two DN300 bonnets

DN450 fitted with two DN300 bonnets

DN500 fitted with two DN350 bonnets

Note: These valves are not suitable for use with Group 1 (Dangerous) Gases



Large A Type valves installed in a distillery

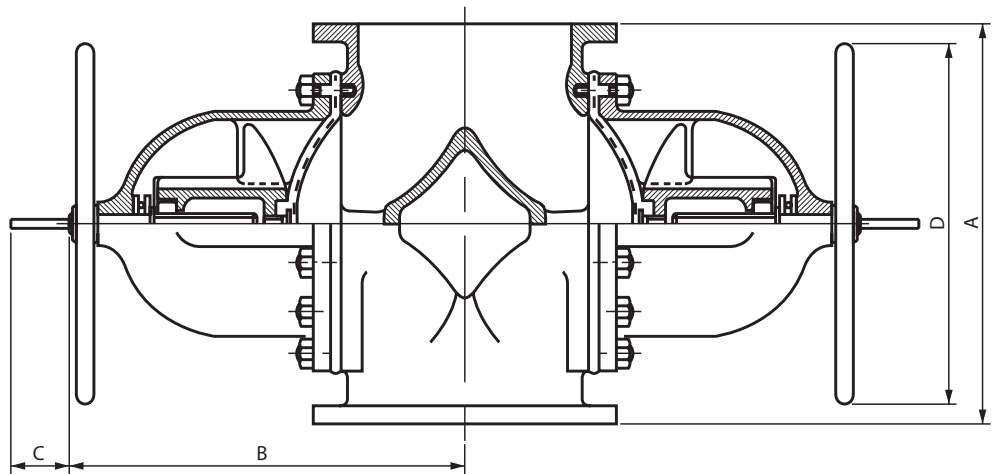

Size DN	A	B	C (TRAVEL)	D
400	750	750	190	700
450	750	750	190	700
500	750	780	230	700

Manual Bonnet Options for A Type Valves

Standard Range

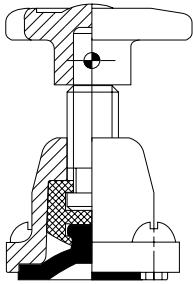

Rising Handwheel
Valve sizes: DN8 to DN10

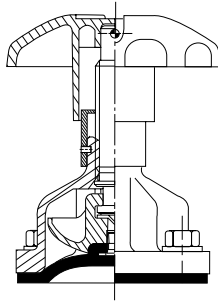

Cast Iron Rising Handwheel Bonnet
Valve sizes: DN15 to DN50



Cast Iron Rising Handwheel
Valve sizes: DN65 to DN150

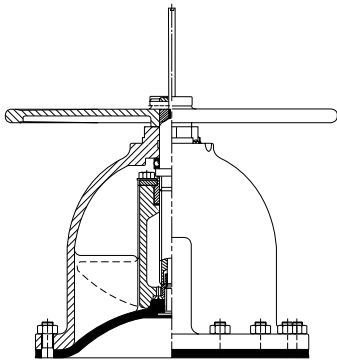

Non-rising Handwheel with Indicator
Valve sizes: DN200 to DN300

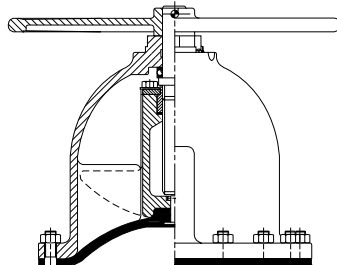

Non-rising Handwheel without Indication
Valve sizes: DN200 to DN350

High Performance Range

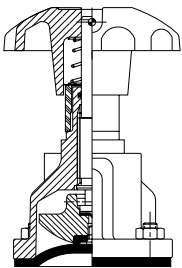

Fluor elastomer Sealed Bonnet
Valve sizes: DN15 to DN150*

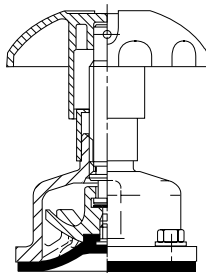

Stainless Steel
Valve sizes: DN15 to DN150*

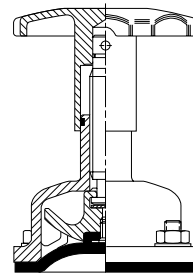

Stainless Steel (Silicone Sealed)
Valve sizes: DN8 to DN80

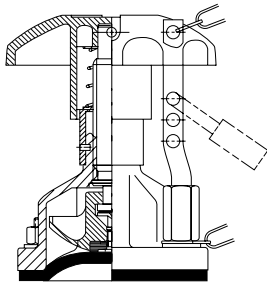

Rising Handwheel Indicator
(simple padlocking)
Valve sizes: DN15 to DN150*

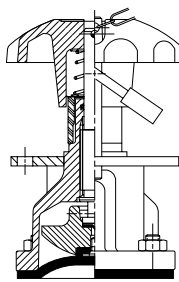

Fluor elastomer Sealed Padlocking
Valve sizes: DN15 to DN150*

* Handwheel is spoked design DN65 – DN150

Saunders WFB Type Valves

For Marine and Firefighting Applications

The WFB valve is a weir type diaphragm valve developed to overcome conventional valve problems on fire fighting, tank cleaning and wash-down on land or sea, wherever guaranteed valve operation is needed.

There are no second chances with a defective fire hydrant valve. Saunders WFB model provides dependable operation when it matters – even after years of non-use.

This highly specialised fire hydrant valve has been tested and approved by the world's leading safety agencies. Similar in design and operation to the widely used A Type, it has the added benefit of a certified chlorosulphonated polyethylene base fire resistant diaphragm. The WFB valve is available in SG iron or gunmetal providing high mechanical strength. This means that they provide greater resistance to accidental impact. Gunmetal resists corrosion on the more demanding applications.



Model 11 with body and bonnet material in gunmetal.



Model 4 with body and bonnet material in SG Iron

Diaphragms

Fire mains use:

- ◆ 286 grade 'Fire' diaphragm
- ◆ 233 CV grade diaphragm (tank cleaning)

Flanges

- ◆ BS10 Tables D, E and F (Gunmetal & SG)
- ◆ BS4504 PN16
- ◆ DIN 86021 ND16 and ANSI B16.24 Class 150 (Gunmetal)
- ◆ EN1092-2 PN16 and ANSI B16.1 Class 150 (SG Iron)

Main Body Inlet/Outlet Body Options

Screwed	Flanged
BS 21RP	BS4504 PN16
BS 21RP	ANSI Class 150
BS 21RP	BS10 Table D
BS 21 RP	JIS10K

ANFT 7.5 TPI
(American National Fire thread)
Male or female

(Other screwed and flanged connections available on request)

Valve Weights (kg)

Model	4	9	11
Gunmetal	10.3	10	11.5
S.G. Iron	8	7.8	8.95



Model 4 with body and bonnet material in gunmetal.

Model 4

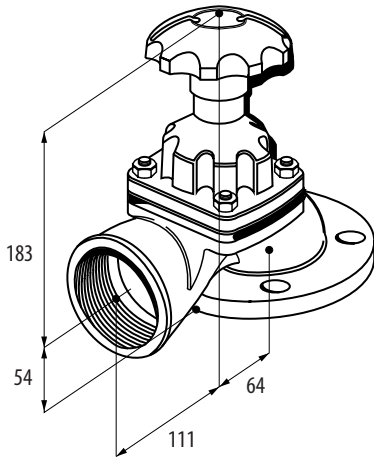
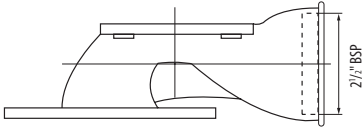

Model 11

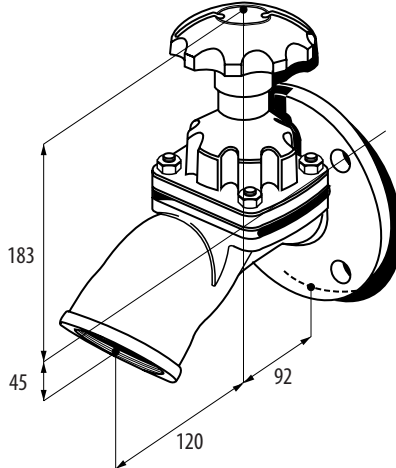
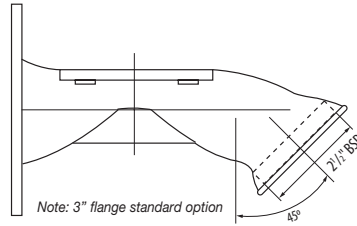

Model 9

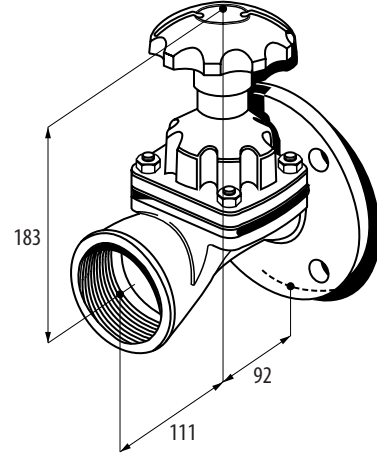
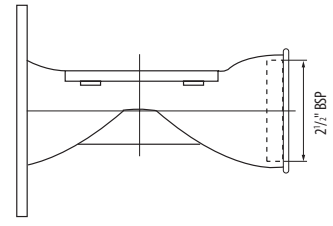

Model 1

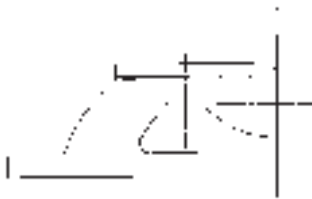

Model 2

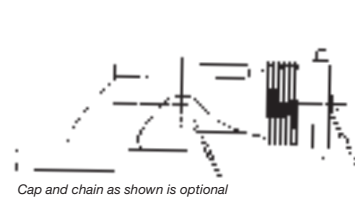

Cap and chain as shown is optional

Model 6

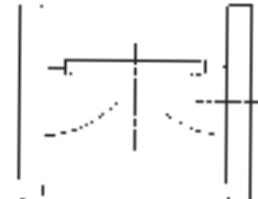

Model 7

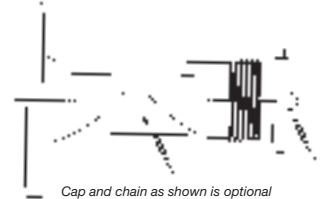

Cap and chain as shown is optional

BODY MATERIALS

	1	2	4	6	7	9	11	
DN40	-	✓	✓	-	✓	✓	-	Gunmetal
DN65	✓	✓	✓	✓	✓	✓	✓	Gunmetal and SG Iron

Testing Valves tested in accordance with BS 6755 i.e. body strength test to 22.5 bar, seat test to 16.5 bar (1.1 x maximum working pressure)

"We specified Saunders WFB 65mm nominal bore fire-mains hydrant valves for our ferries and cruise liners. Significant factors behind this choice are excellent reliability and the low maintenance costs".
P&O Cruises (UK) Ltd

Product approvals



Det Norske Veritas
 Register of Type Approval
 Products No. 5: Mechanical
 Equipment and Piping 1997/98
 Page 54
 Certificate No: P-9951
 Model No: DN65



Marine Safety Agency
 The Department of Transport
 Certificate of Inspection and Tests
 Certificate No: SUR 222 (REV 4/94)
 Model No: DN40, DN65



Lloyds Register of Shipping
 LR Type Approval Certificate
 Certificate No: 97/00047
 Model No: DN40, DN65



Bureau Veritas
 Type Approval Certificate
 Certificate No: 2207 3457 C10 H
 Model No: DN40, DN65



Registro Italiano Naval
 Rina
 Type Approval
 Certificate No: MAC/057/94
 Model No: DN65



American Bureau of Shipping
 List of Type Approved Equipment
 Page 25.
 Certificate No: 96-WM10305-X
 Model No: DN40, DN65

- American Bureau of Shipping
- UK Marine Safety Agency
- Bureau Veritas
- Det Norske Veritas
- Rina
- Lloyds
- DTI

The whole valve has successfully undergone a high temperature resistance test, BS 5041 Part 1, audited by a Lloyds Surveyor.

Saunders KB Type Diaphragm Valves

Straight Through Bores

Saunders full bore KB type diaphragm valves, with their smooth non-turbulent body design have proved to be outstanding in resisting the erosive effects of corrosive and corrosive/abrasive line media. In addition, the full bore concept is designed for minimum flow resistance whilst allowing rodding out and easy cleaning.

Low pressure drop and high flow characterise the efficiency of operation of these valves. The flexible diaphragm ensures consistent leak tightness even when solids, powders and dry media are present. Valve blockage and wear due to slurry build up on the valve internals are significantly reduced by the straight through design.

In addition to the range of unlined screwed and flanged bodies, rubber linings and glass coatings are available for the more exacting corrosive and abrasive applications to a maximum working pressure of 10 bar.

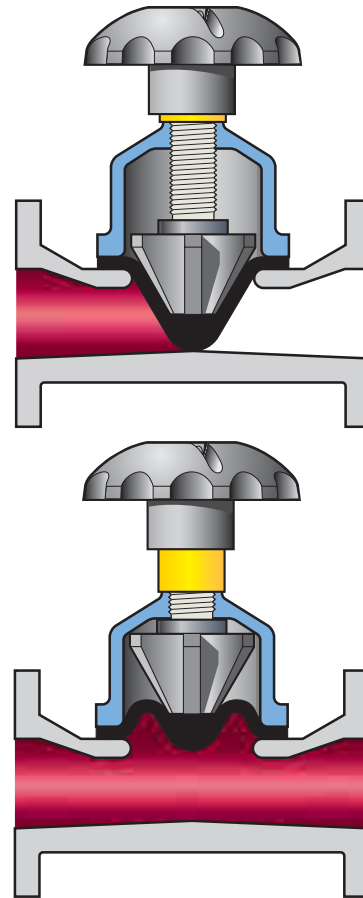

Features	Benefits
Straight through body, high flow	No obstruction, low pressure drop
Flexible closure even with solids present	Leaktight by design
Only two wetted parts	Better resistance to corrosion/abrasion and longer life
Specially developed linings and diaphragms available	Minimal maintenance

Valve flow

Smooth bore straight through body gives high flow performance with minimum turbulence, while giving 100% leaktight closure.

Lubrication

Bonnet assembly lubricated for long life. Needs no further grease. The indicator lip seal stops the ingress of dust, dirt and atmospheric contaminants.

Ease of maintenance

Three part design allows maintenance and actuator retrofitting without removing the valve body from the pipeline. Extended life, reliability and safety, combined with essentially simple design, result in low maintenance and low cost of ownership.

Valve usable in any position

The KB valve can be installed in any position without affecting its operation. We recommend six times pipe diameter from pump or bend.

Saunders KB Type Design Features

Contribute to low pressure drop high flow capability and long valve life

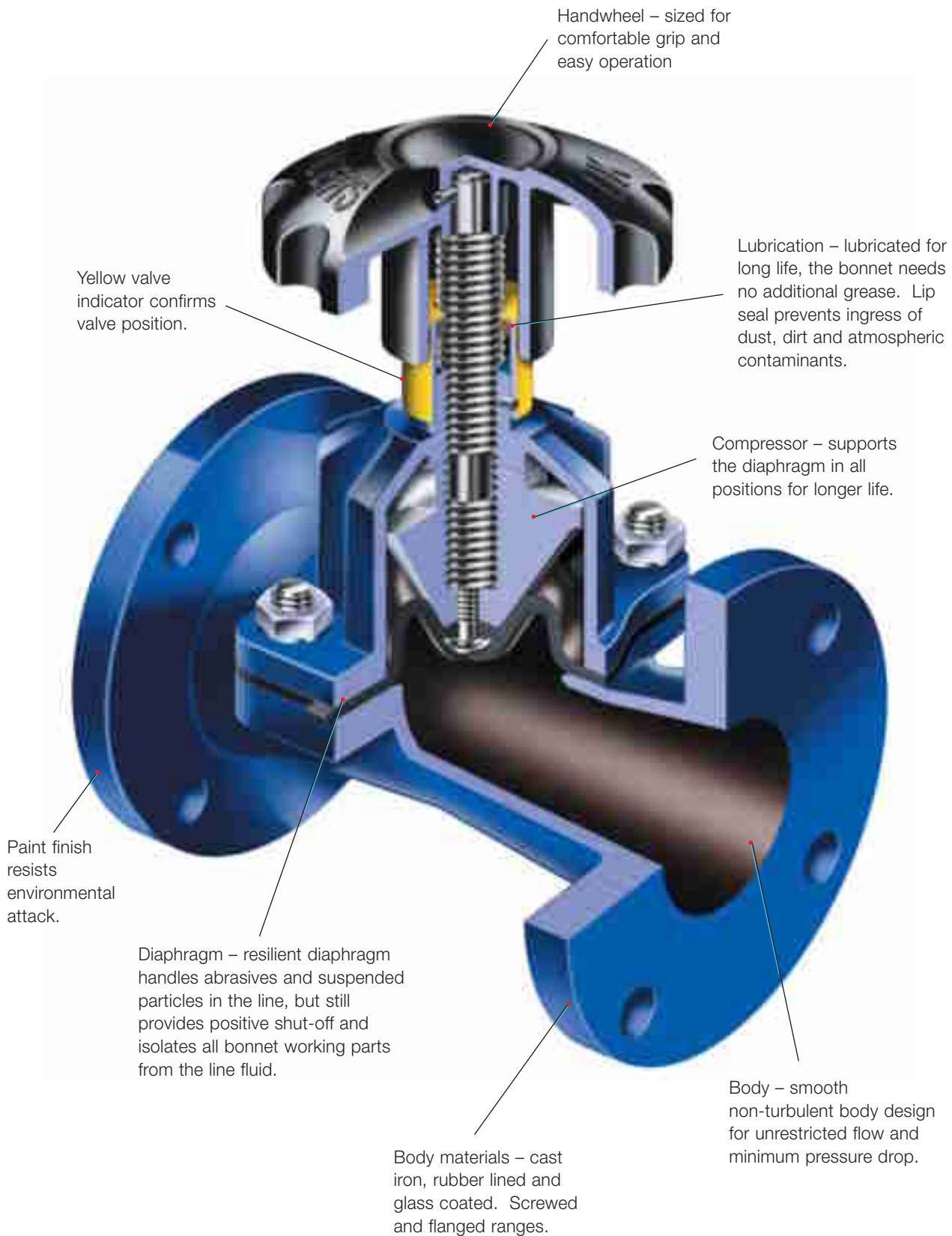

Saunders KB Type Diaphragm Valves

Materials of Construction

Valve bodies

CAST IRON, GUNMETAL
Screwed DN15 – DN50

CAST IRON, GUNMETAL
Flanged DN15 – DN350*

* Contact us for materials range

Rubber lined body data

- ◆ Soft rubber linings
 - Natural (Polyisoprene), 40–46° IRHD
 - Polychloroprene, 72–78° IRHD
 - Butyl (Isobutylene isoprene), 60–66° IRHD
- ◆ Hard ebonite rubber HRL, 75–85° Shore D
- ◆ Lining thickness range 2–4.5mm (DN20–DN350)

Valve body lining – production tests

All Saunders lined valves have each body individually tested for lining integrity.

- ◆ Glass lining – Spark test 10kV ac
- ◆ Rubber, Butyl, Polychloroprene, Natural – Spark test 14kV ac/dc
- ◆ Rubber, HRL – Spark test 17kV ac/dc

Material	Grade
Fluoroelastomer	226
Polychloroprene	HT
Nitrile	C
Butyl	300
EPM	425
Natural Rubber	AA

Diaphragm Materials

Grades	Elastomer Type	General Service & Approvals
AA	Natural rubber (polyisoprene) metal oxide pigmented – brown sulphur cured, black reinforced	Abrasives in slurry or dry powder form
C	Butadiene Acrylonitrile, (Nitrile) sulphur cured, black reinforced	Lubricating oil, cutting oils, paraffin, animal and vegetable oils, aviation kerosene
HT	Polychloroprene, sulphur cured, black reinforced	Abrasives slurries containing hydrocarbons
226	Fluoroelastomer, amine cured, black reinforced	Concentrated acids, aromatic solvents, chlorinated solvents, unleaded petroleum
300	Isobutylene Isoprene, resin cured black reinforced	Abrasive slurries, acid digested slurries, alkalis, dry powders
425	Ethylene propylene (EPM) organic peroxide cured, black reinforced	Abrasive slurries, acid digested slurries, alkalis, dry powders

Diaphragm Materials – Visual Process Resistance Guide

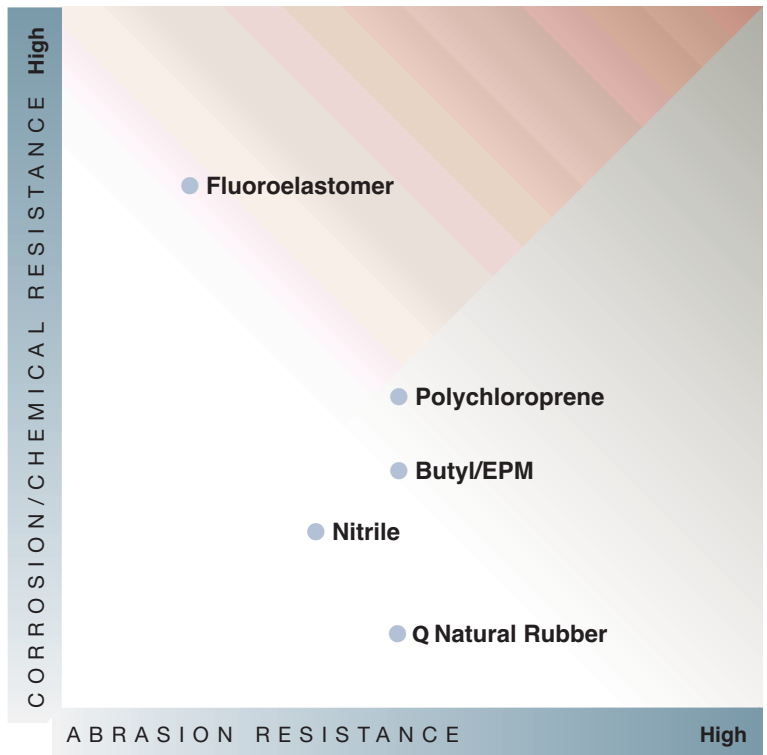

Size DN	15	20	25	32	40	50	65	80	100	125	150	200	250	300	350
Non-rising handwheel												3.5	3.5	3.5	1.5
Rising Handwheel	10	10	10	10	10	10	10	10	10	6	6				

Maximum working pressure for KB valves shown is for manual valves, defined as the maximum line pressure against which valves may be operated to closed position up to and including 55°C. For ES actuators, please refer to appropriate actuator performance selection technical data sheets.

Saunders KB Type Diaphragm Valves

Endurance Bonnet

Saunders Endurance Bonnet is a serviceable bonnet assembly developed for the KB straight through diaphragm valve, specifically for the mineral processing industry, in particular the phosphate, and precious metal sector.

To meet market requirements, the bonnet was designed to allow easy replacement of a range of spare parts which protect the interior of the valve from the aggressive and corrosive environment.

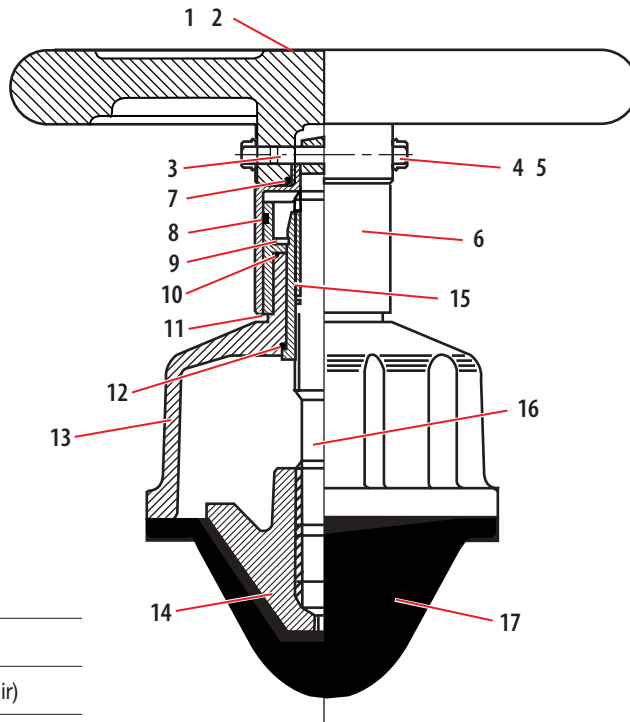

Features

- ◆ Rising handwheel
- ◆ Yellow visual indicator
- ◆ Indicator sleeve (lubrication reservoir)
- ◆ 'O' ring sealed
- ◆ Screw plug & 'O' ring protection
- ◆ Serviceable Insert
- ◆ Bonnet epoxy coated surface finish
- ◆ Spares kit

Bonnet size range

- ◆ KB Type : DN65 to DN150

MATERIALS OF CONSTRUCTION

Item	Component	Material	Finish
1	LABEL	Polyester	Bright silver
2	HANDWHEEL	Cast Iron	Alkyd paint
3	HANDWHEEL PIN	Steel	Zinc plate/passivate
4	SCREW PLUG	Plastic	Black HDPE
5	'O' RING	Nitrile	
6	HANDWHEEL BOSS	Polypropylene	Black
7	'O' RING	Nitrile	
8	'O' RING	Nitrile	
9	CIRCLIP	Steel	
10	'O' RING	Nitrile	
11	BONNET SLEEVE	Aquanyl	Yellow
12	'O' RING	Nitrile	
13	BONNET	Cast Iron	Epoxy paint
14	COMPRESSOR	Cast Iron	Phosphate
15	BONNET INSERT	Carbon Steel	Phosphate
16	SPINDLE	Carbon Steel	Phosphate
17	DIAPHRAGM	As specified	

Saunders KB Type Diaphragm Valves

Flow Co-efficients of Valve Range Cv (Kv)

DN 25	BODY MATERIAL / LINING					
	Cast iron		Rubber Lined		Glass	
	Cv	Kv	Cv	Kv	Cv	Kv
% Open						
100	37.80	32.40	30.60	26.20	39.00	33.40
90	35.10	30.10	28.40	24.30	36.00	30.87
80	32.10	27.51	26.04	22.32	33.00	28.30
70	29.10	24.94	23.60	20.20	30.00	25.70
60	26.50	22.71	21.40	18.40	27.30	23.40
50	22.70	19.50	18.40	15.78	23.40	20.10
40	18.90	16.20	15.30	13.10	19.50	16.71
30	14.00	12.00	11.30	9.70	14.40	12.30
20	9.10	7.80	7.30	6.30	9.40	8.10
10	4.50	3.86	3.70	3.20	4.70	4.00
0	0	0	0	0	0	0

DN 50	BODY MATERIAL / LINING					
	Cast iron		Rubber Lined		Glass	
	Cv	Kv	Cv	Kv	Cv	Kv
% Open						
100	128.00	110.00	107.00	91.70	138.00	118.00
90	119.00	102.00	99.00	85.00	128.00	110.00
80	109.00	93.00	91.00	78.00	117.00	100.00
70	99.00	85.00	82.00	70.00	106.00	90.90
60	90.00	77.00	75.00	64.00	97.00	83.00
50	77.00	66.00	64.00	55.00	83.00	71.00
40	64.00	55.00	53.00	45.00	69.00	59.00
30	47.00	40.00	40.00	34.00	51.00	44.00
20	31.00	27.00	26.00	22.00	33.00	28.00
10	15.00	12.86	12.80	11.00	16.60	14.00
0	0	0	0	0	0	0

DN 65	BODY MATERIAL / LINING					
	Cast iron		Rubber Lined		Glass	
	Cv	Kv	Cv	Kv	Cv	Kv
% Open						
100	238	204	195	167	254	218
90	221	189	181	155	236	202
80	202	173	166	142	216	185
70	183	157	150	129	196	168
60	167	143	136	117	178	153
50	143	123	117	100	152	130
40	119	102	97	83	127	109
30	88	75	72	62	94	81
20	57	49	47	40	61	52
10	29	25	23	19	20	26
0	0	0	0	0	0	0

DN 80	BODY MATERIAL / LINING					
	Cast iron		Rubber Lined		Glass	
	Cv	Kv	Cv	Kv	Cv	Kv
% Open						
100	330	293	264	226	342	293
90	307	263	246	211	318	273
80	281	241	224	192	291	249
70	254	218	203	174	263	225
60	231	198	185	159	239	205
50	198	170	159	136	205	176
40	165	141	132	113	171	146
30	122	105	98	84	127	109
20	79	68	63	54	82	70
10	40	34	32	27	41	35
0	0	0	0	0	0	0

DN 100	BODY MATERIAL / LINING					
	Cast iron		Rubber Lined		Glass	
	Cv	Kv	Cv	Kv	Cv	Kv
% Open						
100	588	504	480	411	618	528
90	547	469	446	382	575	493
80	500	429	408	350	525	450
70	453	388	370	317	476	408
60	412	353	336	288	433	371
50	353	303	288	247	371	318
40	294	252	240	206	309	265
30	218	187	178	153	229	196
20	141	121	115	99	148	127
10	71	61	58	50	74	63
0	0	0	0	0	0	0

DN 125	BODY MATERIAL / LINING					
	Cast iron		Rubber Lined		Glass	
	Cv	Kv	Cv	Kv	Cv	Kv
% Open						
100	924	792	720	617	960	823
90	859	736	670	574	893	765
80	785	673	612	525	816	699
70	711	609	554	475	739	633
60	647	555	504	432	672	576
50	555	475	432	370	576	494
40	462	396	360	309	480	411
30	342	293	266	228	355	304
20	222	190	173	148	230	197
10	111	95	86	74	115	99
0	0	0	0	0	0	0

DN 150	BODY MATERIAL / LINING					
	Cast iron		Rubber Lined		Glass	
	Cv	Kv	Cv	Kv	Cv	Kv
% Open						
100	1680	1440	1260	1080	1800	1543
90	1562	1339	1172	1005	1674	1435
80	1428	1224	1071	918	1530	1311
70	1294	1109	970	831	1386	1188
60	1176	1008	882	756	1260	1080
50	1008	864	756	647	1080	926
40	840	720	630	540	900	771
30	622	533	466	399	666	571
20	403	345	302	259	432	370
10	202	173	151	129	216	185
0	0	0	0	0	0	0

DN 200	BODY MATERIAL / LINING					
	Cast iron		Rubber Lined		Glass	
	Cv	Kv	Cv	Kv	Cv	Kv
% Open						
100	2580	2211	2196	1882	2724	2335
90	2399	2056	2042	1750	2533	2171
80	2193	1880	1867	1600	2315	1985
70	1987	1703	1691	1449	2097	1797
60	1806	1548	1537	1318	1907	1634
50	1548	1327	1318	1130	1634	1401
40	1290	1106	1098	941	1362	1167
30	955	819	813	697	1008	864
20	619	531	527	452	653	560
10	310	266	264	226	327	280
0	0	0	0	0	0	0

Cv is flow in US gpm through valve at Δ P of 1 psi
Kv is flow in m³/hr through valve at Δ P of 1 bar

For sizes DN15, 32 and 40, please contact customer service department for details.

Saunders KB Type Diaphragm Valves

Valve Dimensions and Weights

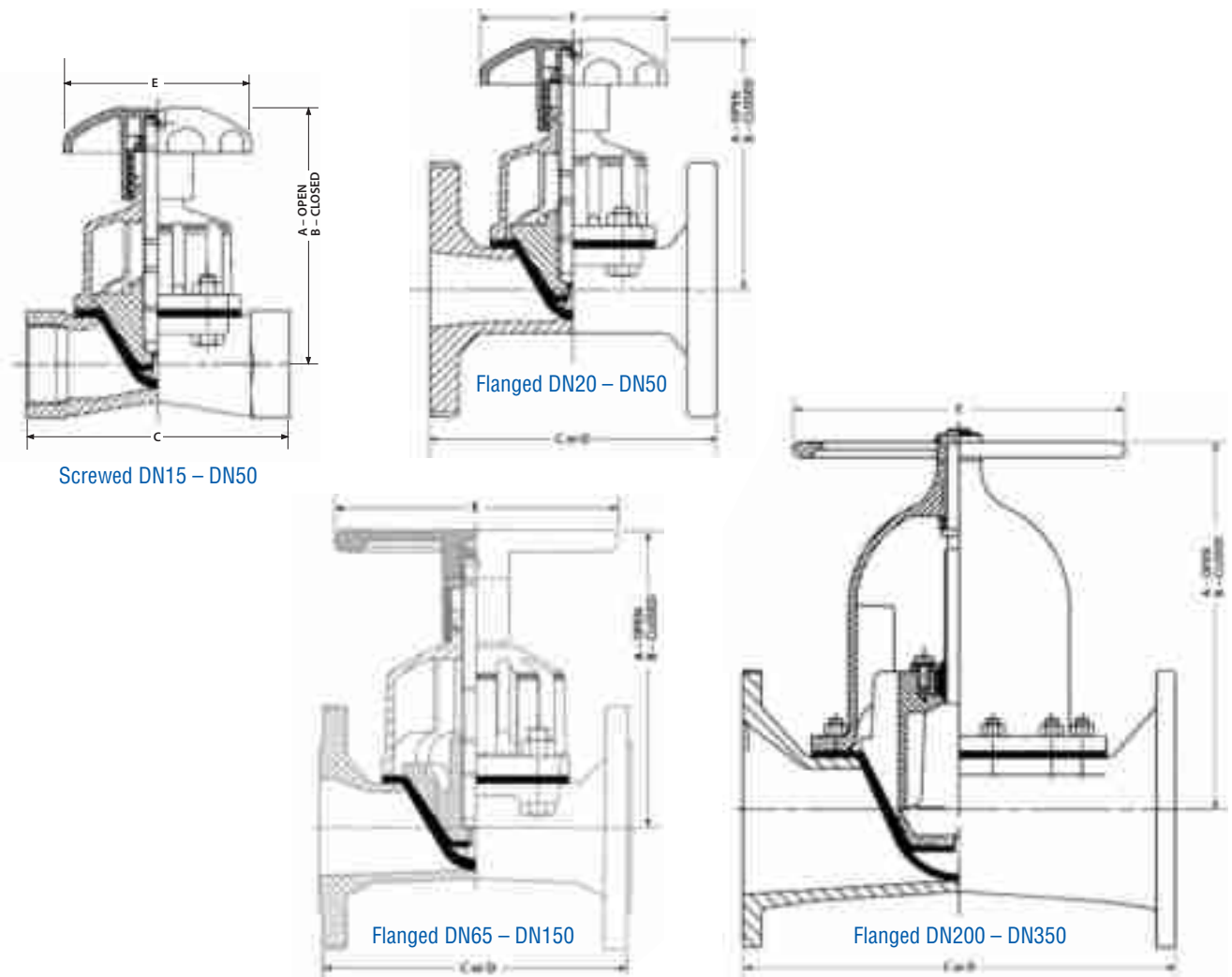

Valve Diameter (DN)

		100	125	150	200	250	300	350								
Screwed	A	106	—	166	—	166	182	—								
	B	98	—	159	—	159	162	—								
	C	63.5	—	111	—	143	168	—								
	Weight	0.82	—	2.0	—	2.7	4.8	—								
Flanged	A	105	105	165	165	165	176	234	270	313	335	435	406	557	628	665
	B	97	97	159	159	159	156	210	238	277	293	379	—	—	—	—
	C	108	117	127	146	159	190	216	254	305	356	406	521	635	749	980
	D	130	150	160	180	200	230	290	310	350	400	480	600	730	850	980
	Weight	2.02	2.31	4.12	4.35	5.45	10.2	11.2	17.9	31.4	46.2	67.3	109	195	294	462
Flanged Rubber Lined	A	—	—	168	168	168	176	234	270	313	335	435	408	559	630	667
	B	—	—	162	162	162	156	210	238	277	293	379	—	—	—	—
	C	—	—	131	150	163	194	220	258	309	362	412	527	641	755	986
	D	—	—	160	180	200	230	290	310	350	400	480	600	730	850	980
	Weight	—	—	4.22	5.65	7.45	10.5	11.6	21.9	34.4	46.2	74.3	127	204	294	465
Flanged Glass Lined	A	—	106	166	166	166	177	235	271	314	336	436	407	558	629	666
	B	—	98	160	160	160	157	211	239	278	294	380	—	—	—	—
	C	—	119	133	148	165	196	222	260	311	364	414	523	637	751	982
	D	—	150	160	180	200	230	290	310	350	400	480	600	730	850	980
	Weight	—	2.52	4.2	5.05	6.95	10.3	11.4	20.3	33.9	46.1	71.6	118	201	294	462
	E	80	80	120	120	120	120	170	230	280	280	368	368	483	584	699

Weights in kg. C valve length = EN 558-1 Series 7 (ex BS 5156). D valve length = EN 558-1 Series 1 (ex DIN 3202 Series F1).

Saunders KB Type Diaphragm Valve Performance

Temperature and Pressure Relationship

Diaphragm Temperatures Type KB (°C)

-40°	AA	90°
-10°	C	90°
-20°	HT	90°
-5°	226	120°
-20°	300	100°
-40°	425	100°

KB Valve Body Temperature/Pressure Relationship

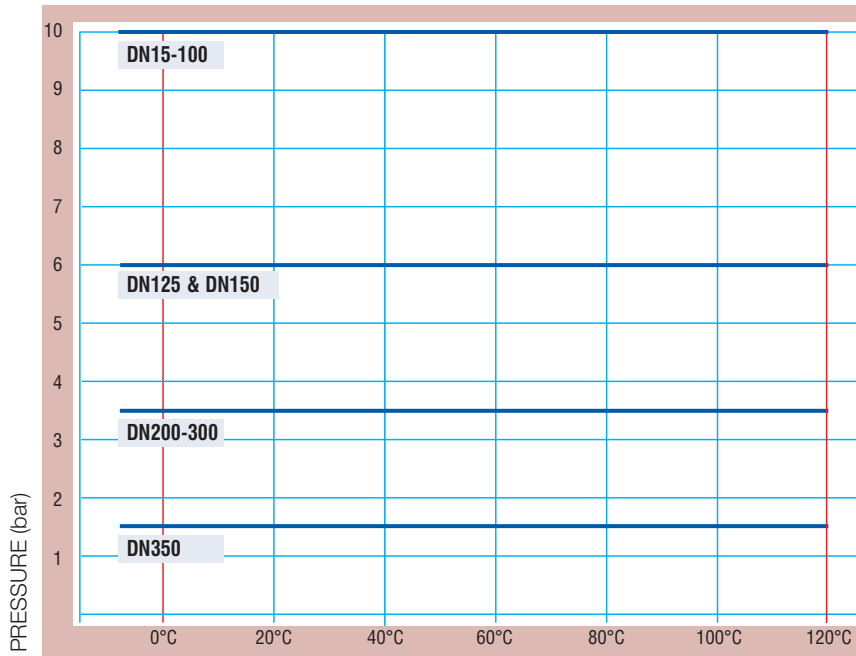

TEMPERATURE °C

Body Temperature Limit (°C)

-10°	CAST IRON	120°
-30°	STAINLESS STEEL /COPPER ALLOYS	120°
-10°	GLASS LINED	120°
-10°	HARD RUBBER LINED	85°
-10°	SOFT NATURAL RUBBER LINED	85°
-10°	BUTYL LINED	110°
-10°	POLYCHLOROPRENE LINED	105°

For whole manual valves refer to 2/KB/005/UK/REV1 and for ES actuated valves refer to appropriate performance graphs.

Saunders KB Type Diaphragm Valves

Typical Bonnet Options for Manual KB Valves

Standard Range

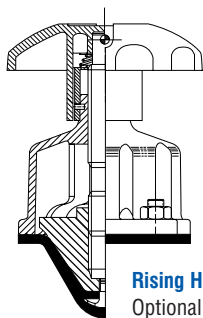

Rising Handwheel Indicator
Optional Metal Handwheel
Valve sizes: DN15 to DN50

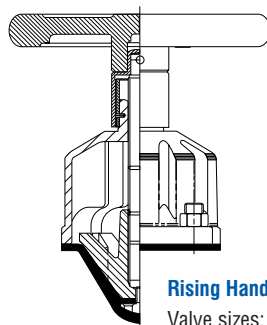

Rising Handwheel Indicator
Valve sizes: DN65 to DN150

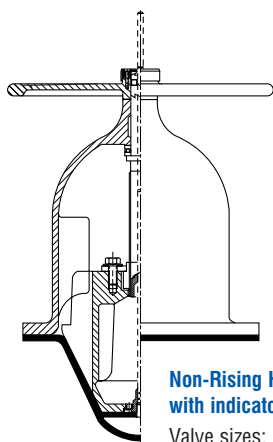

Non-Rising Handwheel with indicator
Valve sizes: DN200 to DN300

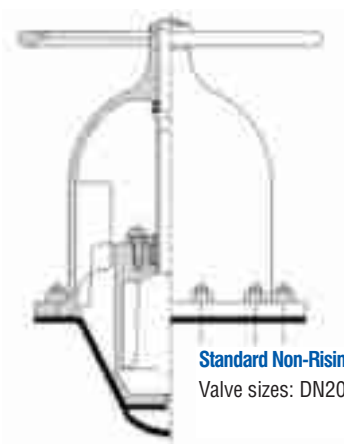

Standard Non-Rising Handwheel
Valve sizes: DN200 to DN350

High Performance Range

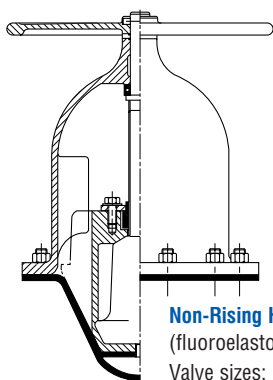

Non-Rising Handwheel
(fluoroelastomer sealed)
Valve sizes: DN15 to DN300

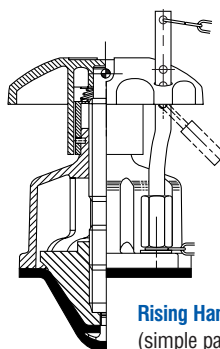

Rising Handwheel Indicator
(simple padlocking)
Valve sizes: DN15 to DN50

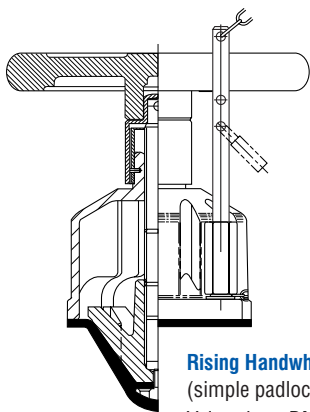

Rising Handwheel Indicator
(simple padlocking)
Valve sizes: DN65 to DN150

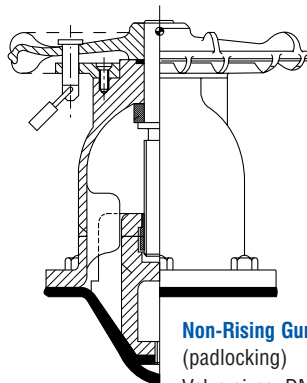

Non-Rising Gunmetal LG4
(padlocking)
Valve sizes: DN15 to DN200

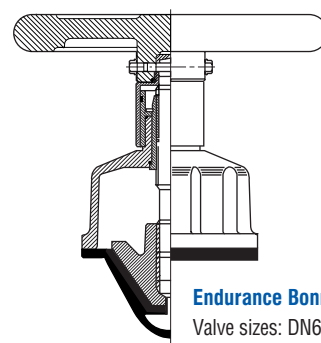

Endurance Bonnet
Valve sizes: DN65 to DN150

Pneumatic Valve Actuation

Compact Actuators that Provide Reliable Remote Control

Saunders EC and SSC Pneumatic Actuators facilitate remote operation of the valve, as an integral part of a control system. Both are compact piston style actuators with excellent chemical and temperature resistance.

The versatile and robust design derived from the use of high technology materials of construction, results in an actuator suitable for a wide range of process industry applications.

All three operation modes, double acting, spring to close and spring to open feature the same physical dimensions for a given valve size. This provides uniform compact envelope dimensions and outstanding economic benefits particularly for spring return failsafe actuation.

Field conversion of manual valves to power actuation is readily achieved 'in-line' without special tools or modification.

EC

The EC is manufactured by injection moulding PES (polyethersulphone), which has a temperature range of -10° to +100°C ambient (autoclave maximum 150°C). Actuators can be supplied as spring close, spring open or double acting with various spring pack options for a variety of pressure requirements.

Size range DN8 – DN50



SSC Actuator

SSC

With the same flexibility as the EC Actuator, the SSC has been manufactured with a 316C12 stainless steel investment cast housing. Suitable for both aseptic and industrial applications the SSC has excellent resistance to both chemical and steam duties.

Size range DN8 – DN50



EC Actuator mounted on A Type PFA lined valve

Pneumatic Valve Actuation

Compact actuators that provide reliable remote control



ECX Actuator with visual indicator

ECX

Available in spring close, spring open and double acting modes of operation to suit process needs. A wide range of options including switches, positioners, limit stop and visual open/close indication are also available.

Size range:
DN65 – DN150

ECX

Saunders ECX type actuators are designed to offer an extension to the EC size range whilst still maintaining the compact envelope size. The housing is manufactured in coated silicon aluminium for increased chemical resistance and long life. With the extensive flexibility in spring packs we can offer an actuator to suit a wide range of pressure and flow variations.



ECX Actuator with switchbox and integral solenoid

Pneumatic Valve Actuation

EV and ES Modular Actuators

The ES Modular Actuator offers efficient mechanical/pneumatic control of the diaphragm, allowing remote and automated operation.

Saunders ES Modular Actuator has been designed to offer full flexibility to the user. Cost of ownership have been reduced through standardization of the Actuator Heads, and a unique interchangeable bonnet assembly.

Several different actuator models may be provided for each valve size to suit different line and operating pressures. The range allows valve closure against the maximum valve working pressure and can be successfully used for modulating control duties in addition to more normal isolation functions.

Failsafe closing actuators are fully adjustable, i.e. spring compression can be externally adjusted to provide optimum diaphragm forces and hence provide extremely long diaphragm life in service.

Many accessory options are available which include solenoid valves, remote indication devices (switches or sensors) to suit environmental conditions such as hazardous services. Limit stops and positioners and many other devices may be offered to allow usage within particular control systems. ES Modular Actuators are provided with a tough polyester coating which gives maximum durability, even in exposed locations.



*ES Modular
(DN15-150)*



*EV spring close
(DN15-150)*



Pneumatic Valve Actuation

Valve Throttling and Flow Control

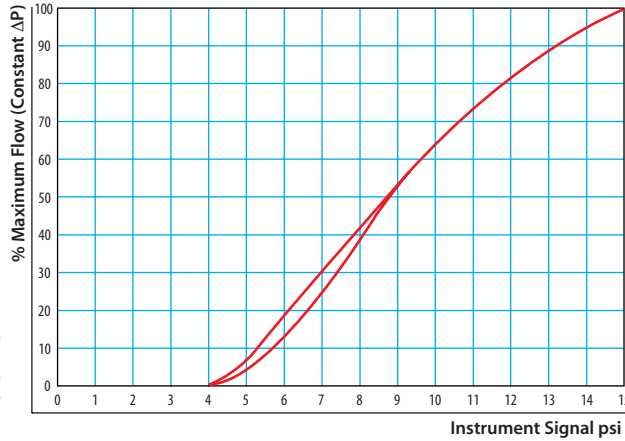

Saunders diaphragm valves offer excellent control capabilities within a broad range of pressure, flow or level control applications.

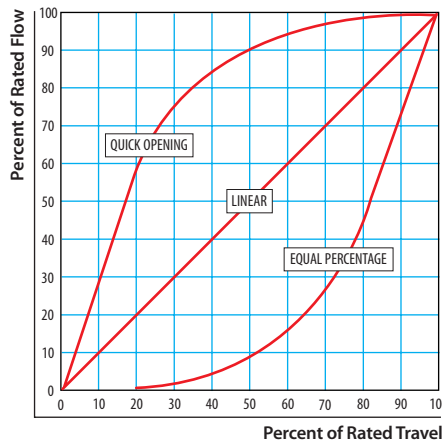

Rangeability (ratio of maximum flow vs. minimum control flow) of Saunders weir type valves is 35:1 extending beyond the range of most process and service control systems.

The positive shut-off characteristics of the valve can, in many instances, eliminate the need for independent block valves, a major component in the piping system cost.

The inherent flow characteristics illustrated shows linearity up to 60% of travel (80% of flow).

The chart illustrates installed characteristics affected by the dynamic friction loss for the remainder of the piping system. Equal % characteristics can be obtained through the use of characterised positioners.

Pressure recovery factor = 0.7.

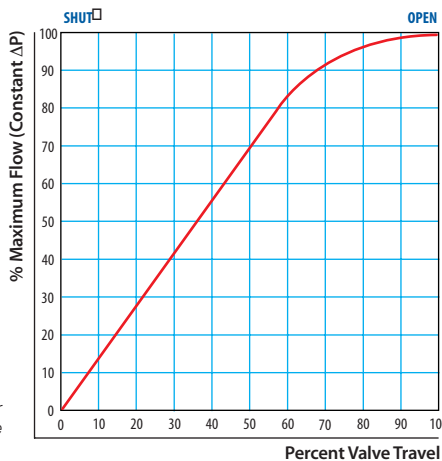

TECHNICAL DATA

EC Pneumatic Actuators DN8 – DN50

Materials of Construction

MATERIALS OF CONSTRUCTION EC/SC

Item	Component	Material
1	Indicator seal	Fluoroelastomer
2	Cap washer	PES (DN8-DN25) IXEF (DN40-DN50)
3	Cap	PES (DN8-DN25) IXEF (DN40-DN50)
4	Loading plate	Mild steel
5	Outer spring	Steel
6	Inner spring	Steel
7	Bonnet cap 'O' ring	Nitrile
8	Indicator	IXEF
9	Outer piston seal	Fluoroelastomer
10	Piston	PES (DN8-DN25) IXEF (DN40-DN50)
11	Inner piston seal	Nitrile
12	Bonnet washer	PES
13	Spindle seal	Fluoroelastomer
14	Spindle	IXEF
15	Bonnet insert	PES (DN40-DN50)
16	Bonnet	PES
17	Line diaphragm	Rubber, Rubber/PTFE
18	Compressor	Mazak (DN8), Mild Steel (DN15-25), Silicon Aluminium (DN15-DN50)

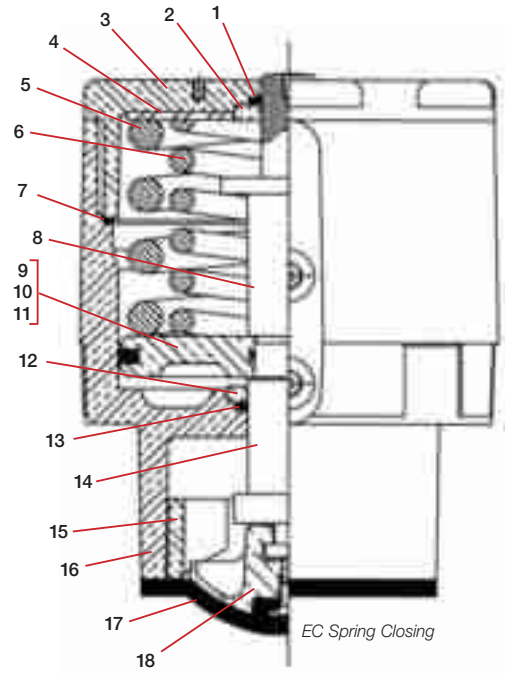

MATERIALS OF CONSTRUCTION EC/SO

Item	Component	Material
1	Indicator	IXEF
2	Indicator seal	Fluoroelastomer
3	Cap washer	PES (DN8-DN25) IXEF (DN40-DN50)
4	Cap	PES (DN8-DN25) IXEF (DN40-DN50)
5	Outer spring	Steel
6	Inner spring	Steel
7	Bonnet cap 'O' ring	Nitrile
8	Spring support plate	PES
9	Outer piston seal	Fluoroelastomer
10	Piston	PES (DN8-DN25) IXEF (DN40-DN50)
11	Inner piston seal	Fluoroelastomer
12	Bonnet washer	PES
13	Spindle seal	Fluoroelastomer
14	Spindle	IXEF
15	Bonnet insert	PES (DN40-DN50)
16	Bonnet	PES
17	Line diaphragm	Rubber, Rubber/PTFE
18	Compressor	Mazak (DN8) Mild Steel (DN15-25) Silicone Aluminium (DN15-DN50)

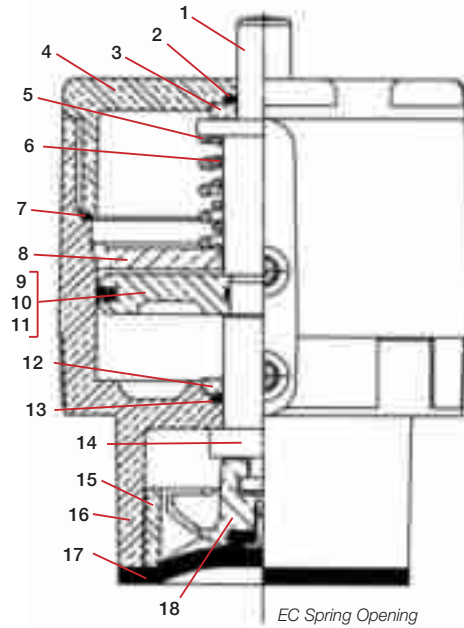

MATERIALS OF CONSTRUCTION EC/DA

Item	Component	Material
1	Indicator seal	Fluoroelastomer
2	Cap washer	PES (DN8-DN25) IXEF (DN40-DN50)
3	Cap	PES (DN8-DN25) IXEF (DN40-DN50)
4	Indicator	IXEF
5	Outer piston seal	Fluoroelastomer
6	Piston	PES (DN8-DN25) IXEF (DN40-DN50)
7	Inner piston seal	Fluoroelastomer
8	Bonnet washer	PES
9	Spindle seal	Fluoroelastomer
10	Spindle	IXEF
11	Bonnet	PES
12	Bonnet insert	PES (DN40-DN50)
13	Line diaphragm	Rubber, Rubber/PTFE
14	Compressor	Mazak (DN8), Mild Steel (DN15-25), Silicon Aluminium (DN15-DN50)

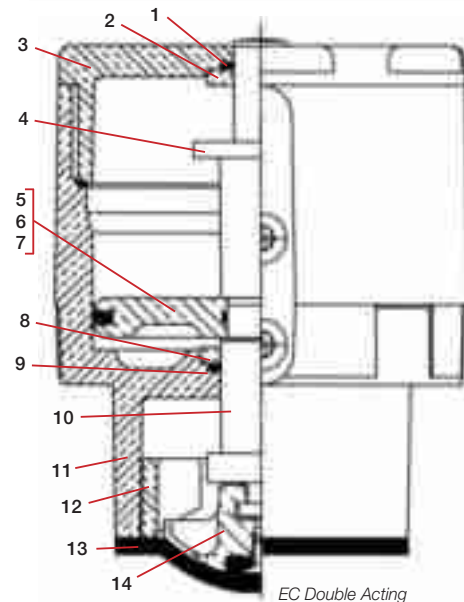

TECHNICAL DATA

SSC (Stainless Steel) Compact Pneumatic Actuators DN8 – DN50

Materials of Construction

MATERIALS OF CONSTRUCTION SSC/SC		
Item	Component	Material
1	Indicator seal	Viton
2	Cap	Stainless Steel
3	Outer spring	Steel
4	Inner spring	Steel
5	Indicator	IXEF
6	Bonnet cap 'O' ring	Nitrile
7	Bonnet	Stainless Steel
8	Outer piston seal	Fluoroelastomer
9	Piston inner 'O' ring	Nitrile
10	Piston	PES (DN8-DN25) IXEF (DN40-DN50)
11	Spindle	IXEF
12	Spindle 'O' ring	Nitrile
13	Thrust pad	Nylatron (DN8-DN20)
14	Line diaphragm	Rubber, Rubber/PTFE
15	Compressor	Stainless Steel
16	Body/bonnet nut	Stainless Steel
17	Body/bonnet washer	Stainless Steel
18	Body/bonnet bolt/stud	Stainless Steel

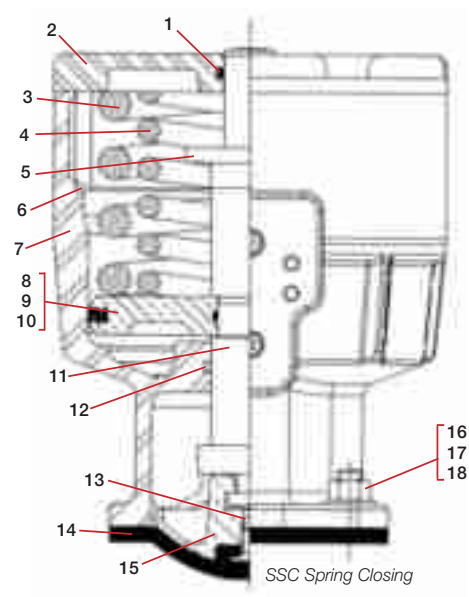

MATERIALS OF CONSTRUCTION SSC/SO		
Item	Component	Material
1	Indicator seal	Viton
2	Cap	Stainless Steel
3	Outer spring	Steel
4	Inner spring	Steel
5	Indicator	IXEF
6	Bonnet cap 'O' ring	Nitrile
7	Bonnet	Stainless Steel
8	Outer piston seal	Fluoroelastomer
9	Piston inner 'O' ring	Nitrile
10	Piston	PES (DN8-DN25) IXEF (DN40-DN50)
11	Spindle	IXEF
12	Spindle 'O' ring	Nitrile
13	Thrust pad	Nylatron (DN8-DN20)
14	Line diaphragm	Rubber, Rubber/PTFE
15	Compressor	Stainless Steel
16	Body/bonnet nut	Stainless Steel
17	Body/bonnet washer	Stainless Steel
18	Body/bonnet bolt/stud	Stainless Steel

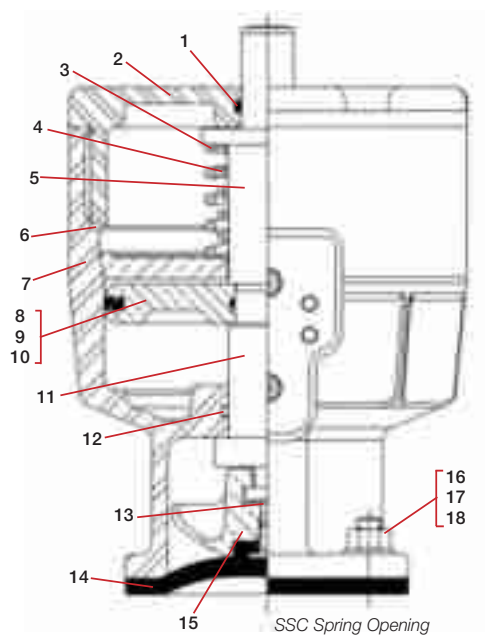

MATERIALS OF CONSTRUCTION SSC/DA		
Item	Component	Material
1	Indicator seal	Viton
2	Cap	Stainless Steel
3	Indicator	IXEF
4	Bonnet cap 'O' ring	Nitrile
5	Bonnet	Stainless Steel
6	Outer piston seal	Fluoroelastomer
7	Piston inner 'O' ring	Nitrile
8	Piston	PES (DN8-DN25) IXEF (DN40-DN50)
9	Spindle	IXEF
10	Spindle 'O' ring	Nitrile
11	Thrust pad	Nylatron (DN8-DN20)
12	Line diaphragm	Rubber, Rubber/PTFE
13	Compressor	Stainless Steel
14	Body/bonnet nut	Stainless Steel
15	Body/bonnet washer	Stainless Steel
16	Body/bonnet bolt/stud	Stainless Steel

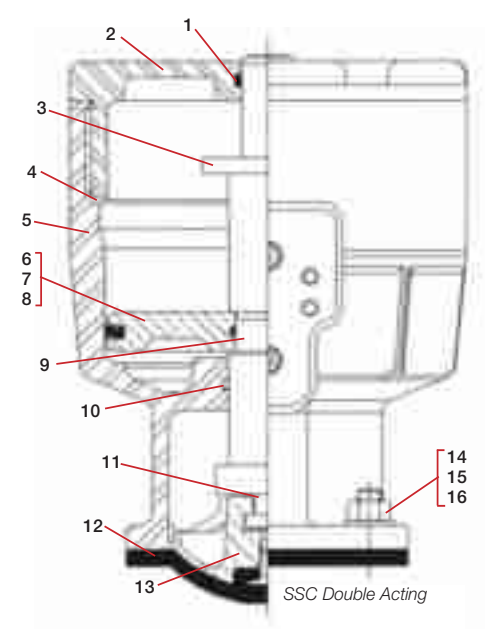

TECHNICAL DATA

ECX Pneumatic Actuators DN65 – DN150

Materials of Construction

MATERIALS OF CONSTRUCTION ECX/SC		
Item	Component	Material
1	Plug	Polyethylene
2	Cover	Silicon aluminium
3	Upper spring plate	SG iron
4	Outer spring	Steel
5	Middle spring	Steel
6	Inner spring	Steel
7	Spring retaining bolt	Mild steel
8	Diaphragm plate	Forged steel
9	Operating diaphragm	Rubber
10	Clamp washer	Mild steel
11	Lower cylinder	Silicon aluminium
12	Cylinder/bonnet bolt	Steel
13	Bonnet 'O' ring	Nitrile
14	Bonnet/cylinder joint	Klingersil
15	Bonnet	Cast iron
16	Spindle	Stainless Steel
17	Compressor pin	Steel
18	Compressor	Cast iron
19	Line diaphragm	Rubber, Rubber/PTFE
20	Screw cover	PE
21	Cylinder cover screw	Steel
22	Cylinder cover nut	Steel
23	Cylinder cover washer	Steel
24	Body/bonnet nut	Stainless steel
25	Body/bonnet stud	Stainless steel
26	Body/bonnet washer	Stainless steel

MATERIALS OF CONSTRUCTION INDICATOR		
Item	Component	Material
1	Indicator cover	Polycarbonate
2	Indicator	Polycarbonate
3	Indicator 'O' ring	Rubber

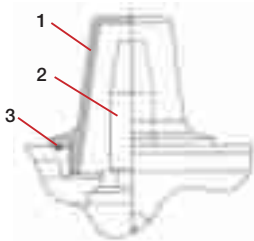

Note: Visual indicator is an optional extra on the ECX.

MATERIALS OF CONSTRUCTION ECX/SO		
Item	Component	Material
1	Cover plug	Mild steel
2	Cover plug 'O' ring	Rubber
3	Spindle screw	Steel
4	Clamp washer	Mild steel
5	Upper cylinder	Silicon aluminium
6	Screw cover	PE
7	Cylinder screw	Steel
8	Cylinder nut	Steel
9	Cylinder washer	Steel
10	Operating diaphragm	Rubber
11	Spacer ring	Silicon aluminium
12	Lower cylinder	Silicon aluminium
13	Diaphragm plate	SG iron
14	Spring	Steel
15	Cylinder/bonnet bolt	Steel
16	Bonnet 'O' ring	Nitrile
17	Bonnet	Cast iron
18	Spindle	Stainless steel
19	Spindle limit pin	Steel
20	Compressor pin	Steel
21	Compressor	Cast iron
22	Line diaphragm	Rubber, Rubber/PTFE
23	Body/bonnet nut	Stainless steel
24	Body/bonnet stud	Stainless steel
25	Body/bonnet washer	Stainless steel

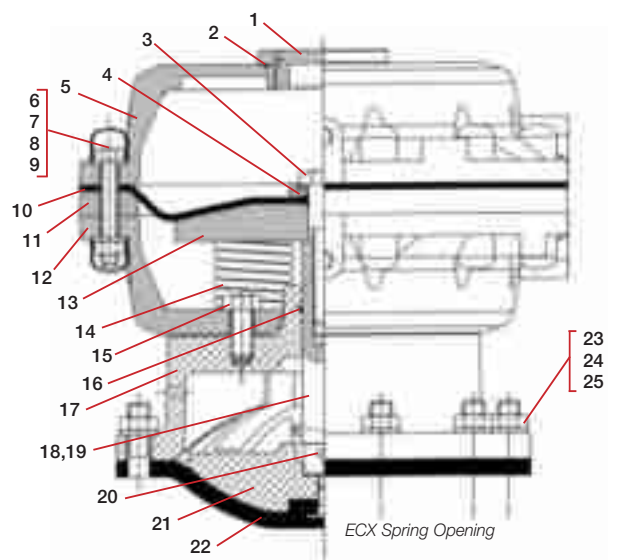
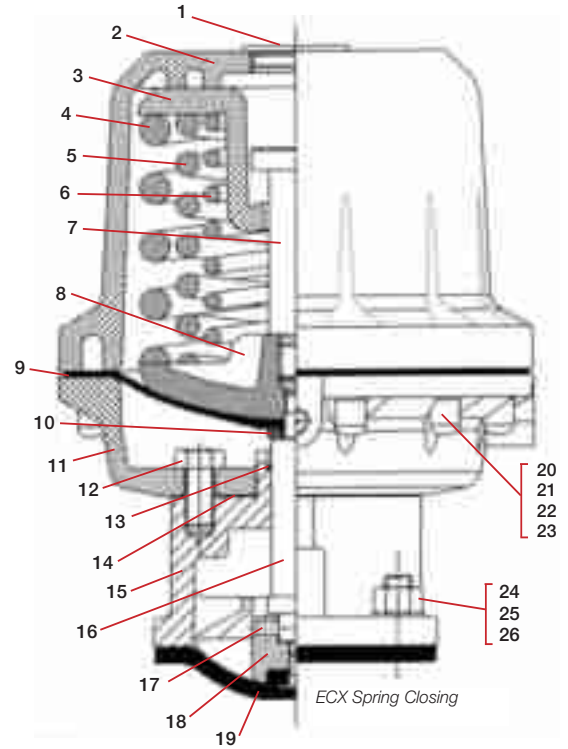

MATERIALS OF CONSTRUCTION ECX/DA		
Item	Component	Material
1	Cover plug	Mild steel
2	Cover plug 'O' ring	Rubber
3	Upper cylinder	Silicon aluminium
4	Spindle screw	Steel
5	Upper diaphragm plate	Mild steel
6	Screw cover	PE
7	Cylinder screw	Steel
8	Cylinder nut	Steel
9	Cylinder washer	Steel
10	Operating diaphragm	Rubber
11	Lower diaphragm plate	Mild steel
12	Lower cylinder	Silicon aluminium
13	Bonnet 'O' ring	Rubber
14	Cylinder/bonnet bolt	Steel
15	Cylinder/bonnet joint	Klingersil
16	Bonnet	Cast iron
17	Spindle	Stainless steel
18	Spindle limit pin	Steel (150mm)
19	Compressor pin	Steel
20	Compressor	Cast iron
21	Line diaphragm	Rubber, Rubber/PTFE
22	Body/bonnet nut	Stainless steel
23	Body/bonnet stud	Stainless steel
24	Body/bonnet washer	Stainless steel

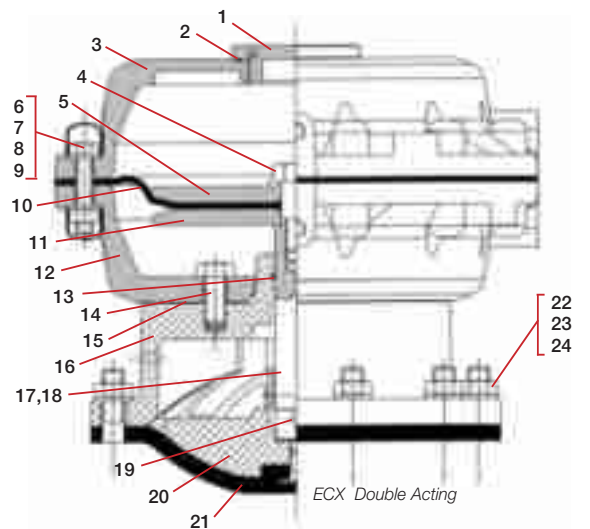

TECHNICAL DATA

ES Modular Pneumatic Actuation DN15 — DN150

Materials of Construction

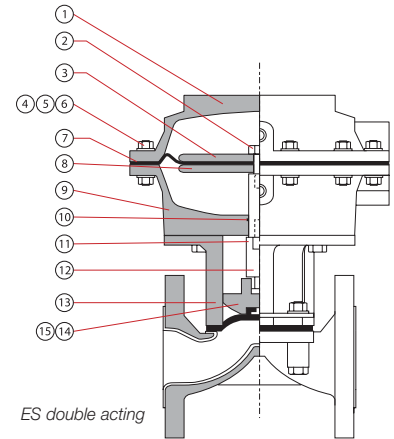
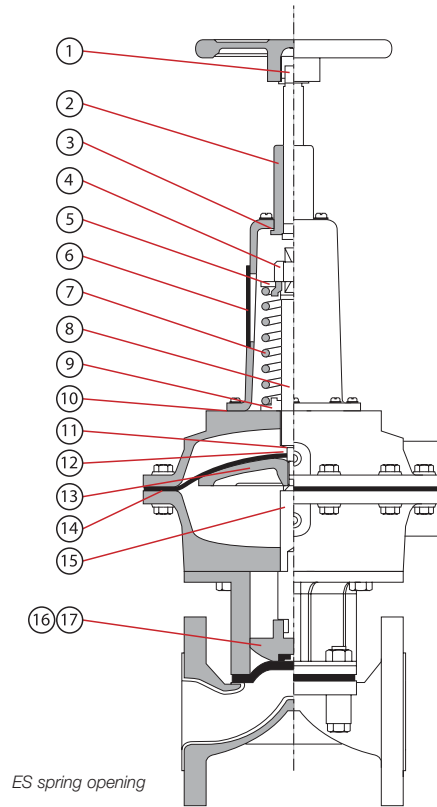
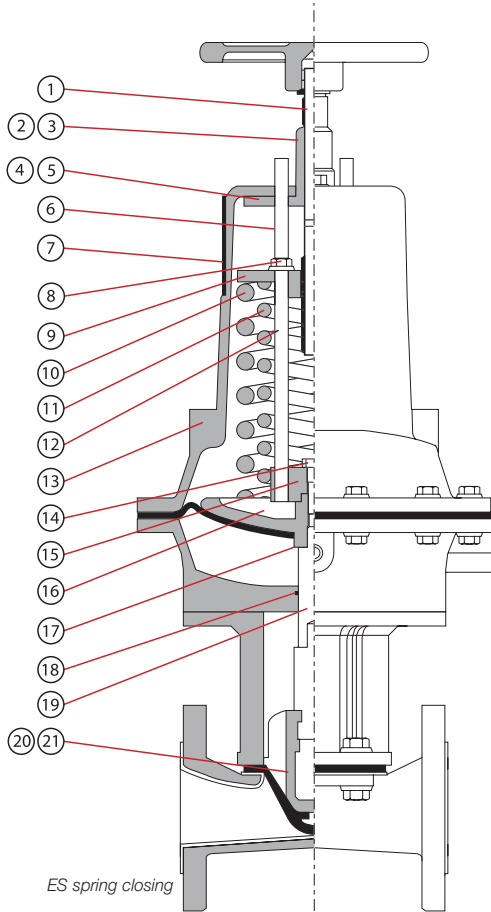

MATERIALS OF CONSTRUCTION ES (SC)		
Item	Component	Material
1	Handwheel Spindle	Mild steel
2	Locking bush	Mild steel
3	Locking bush screw	Steel
4	Reinforcing plate	Forged steel
5	Cover seal	PVC
6	Indicator sleeve	PVC
7	Slot seal	PVC
8	Lifting rod locknut	Steel
9	Upper spring plate	Forged steel
10	Outer spring	Steel
11	Inner spring	Steel
12	Lifting rod	Mild steel
13	Cover	Silicon Alumin
14	Lifting plate screw	Steel
15	Lifting plate	Mild steel
16	Diaphragm plate	Forged steel
17	Clamp washer	Mild steel
18	Lower cylinder o ring	Rubber
19	Master spindle	Stainless steel
20	Compressor pin	Steel
21	Compressor	Cast iron

MATERIALS OF CONSTRUCTION ES (SO)		
Item	Component	Material
1	Handwheel spindle	Mild steel
2	H/wheel spindle bush	Mild steel
3	Cover seal	PVC
4	Adj. screw locknut	Mild steel
5	Upper spring plate	Steel
6	Slot seal	PVC
7	Spring	Steel
8	Adjusting screw	Mild steel
9	Lower spring plate	Mild steel
10	'O' ring	Nitrile
11	Dished washer	Mild steel
12	Clamp washer	Mild steel
13	Diaphragm plate	Forged steel
14	Operating diaphragm	Rubber
15	Master spindle	Stainless steel
16	Compressor pin	Steel
17	Compressor	Cast iron

MATERIALS OF CONSTRUCTION ES (DA)		
Item	Component	Material
1	Upper cylinder	Silicon alumin
2	Diaphragm plate screw	Steel
3	Upper diaphragm plate	Mild steel
4	Cylinder nut	Steel
5	Cylinder bolt	Steel
6	Cylinder washer	Steel
7	Operating diaphragm	Rubber
8	Lower diaphragm plate	Mild steel
9	Lower cylinder	Silicon alumin
10	Lower cylinder 'o' ring	
11	Master spindle	Stainless steel
12	Spindle attachment	Stainless steel
13	Bonnet	Cast iron
14	Compressor pin	Steel
15	Compressor	Cast iron

TECHNICAL DATA

EV Pneumatic Actuation DN15 – DN200

Materials of Construction

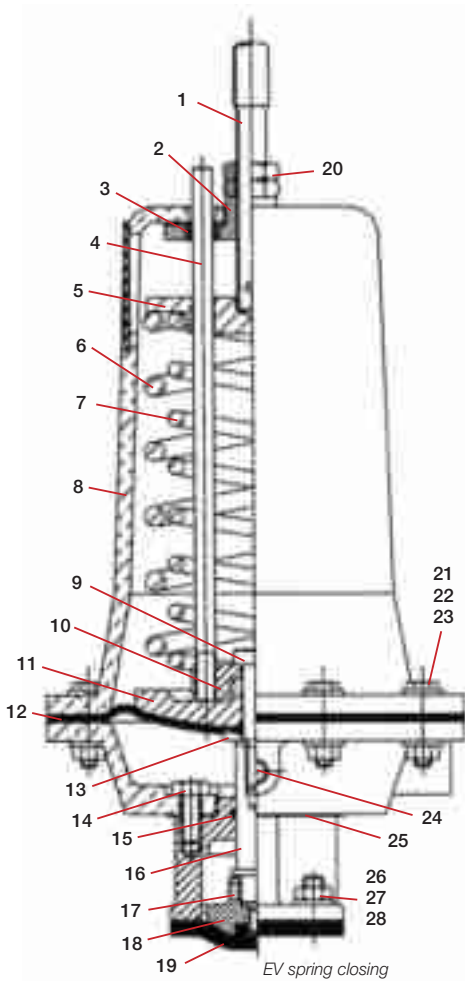

EV spring closing

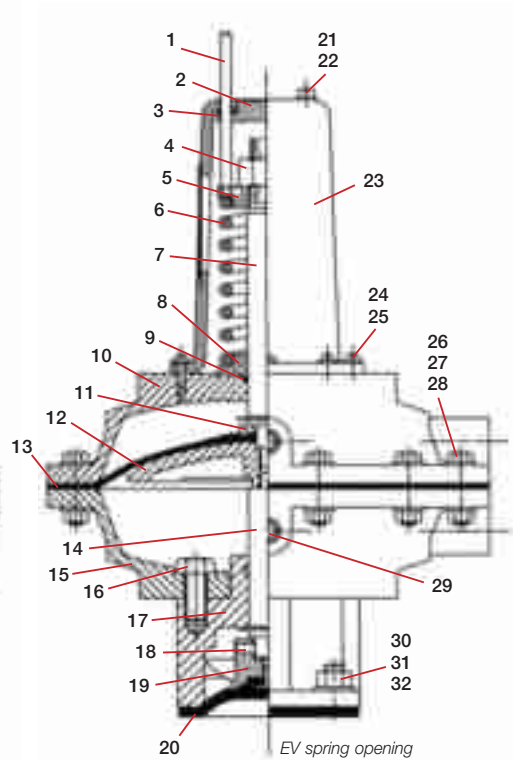

EV spring opening

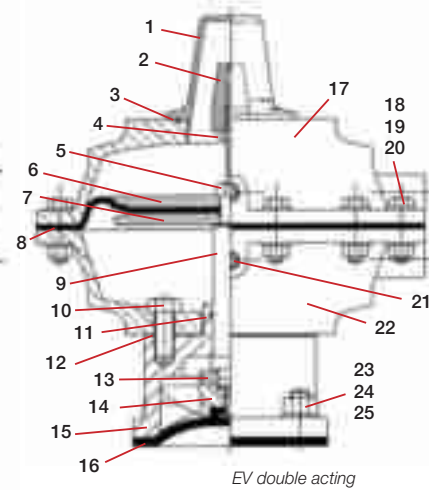

EV double acting

MATERIALS OF CONSTRUCTION EV (SC)

Item	Component	Material
1	Spring adjusting spindle	Steel
2	Reinforcing plate	Forged steel
3	Wiper seal	PVC
4	Indicator rod	Steel
5	Upper spring plate	Forged steel
6	Outer spring	Steel
7	Inner spring	Steel
8	Cover	Silicon aluminium
9	Lifting plate screw	Steel
10	Lifting plate	Mild steel
11	Diaphragm plate	Forged steel
12	Operating diaphragm	Rubber
13	Clamp washer	Mild steel
14	Cylinder/bonnet bolt	Steel
15	Bonnet 'O' ring	Rubber
16	Spindle	Stainless steel
17	Compressor pin	Steel
18	Compressor	Cast iron
19	Line diaphragm	Rubber, Rubber/PTFE
20	Spr. adj. spindle locknut	Steel
21	Cylinder/cover nut	Steel
22	Cylinder/cover bolt	Steel
23	Cylinder/cover washer	Steel
24	Cylinder/bonnet joint	Klingsil
25	Cylinder plug	Malleable iron
26	Body/bonnet nut	Stainless steel
27	Body/bonnet bolt/stud	Stainless steel
28	Body/bonnet washer	Stainless steel

MATERIALS OF CONSTRUCTION EV (SO)

Item	Component	Material
1	Indicator	Steel
2	Cover plug	Mild steel
3	Cover seal	PVC
4	Adjusting screw locknut	Steel
5	Upper spring plate	Forged steel
6	Spring	Steel
7	Adjusting screw	Mild steel
8	Lower spring plate	Mild steel
9	Lower spring plate 'O' ring	Rubber
10	Upper cylinder	Silicon aluminium
11	Clamp washer	Mild steel
12	Diaphragm plate	Forged steel
13	Operating diaphragm	Rubber
14	Spindle	Stainless steel
15	Lower cylinder	Silicon aluminium
16	Cylinder/bonnet screw	Steel
17	Bonnet	Cast iron
18	Compressor pin	Steel
19	Compressor	Cast iron
20	Line diaphragm	Rubber, Rubber/PTFE
21	Cover plug screw	Steel
22	Cover plug washer	Steel
23	Cover	Silicon aluminium
24	Cylinder/cover screw	Steel
25	Cylinder/cover washer	Steel
26	Cylinder nut	Steel
27	Cylinder bolt	Steel
28	Cylinder washer	Steel
29	Cylinder plug	Malleable iron
30	Body/bonnet nut	Stainless steel
31	Body/bonnet bolt/stud	Stainless steel
32	Body/bonnet washer	Stainless steel

MATERIALS OF CONSTRUCTION EV (DA)

Item	Component	Material
1	Indicator cover	Polyamide 6-3-T
2	Indicator	Solid nylon
3	Indicator cover 'O' ring	Rubber
4	Indicator locknut	Steel
5	Diaphragm plate screw	Steel
6	Upper diaphragm plate	Mild steel
7	Lower diaphragm plate	Mild steel
8	Operating diaphragm	Rubber
9	Spindle	Stainless steel
10	Cylinder/bonnet screw	Steel
11	Bonnet 'O' ring	Rubber
12	Cylinder/bonnet joint	Klingsil
13	Compressor pin	Steel
14	Compressor	Cast iron
15	Bonnet	Cast iron
16	Line diaphragm	Rubber, Rubber/PTFE
17	Upper cylinder	Silicon aluminium
18	Cylinder bolt	Steel
19	Cylinder nut	Steel
20	Cylinder washer	Steel
21	Cylinder plug screw	Malleable iron
22	Lower cylinder	Silicon alumin
23	Body/bonnet bolt nut	Stainless steel
24	Body/bonnet bolt stud	Stainless steel
25	Body/bonnet washer	Stainless steel

TECHNICAL DATA

EC/SSC/ECX Actuator Dimensions

EC/SSC

Size DN	A	B
15	115	110
20	160	152
25	168	161
40	231	217
50	249	229

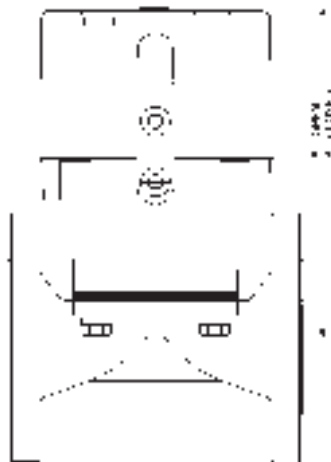

EC actuator

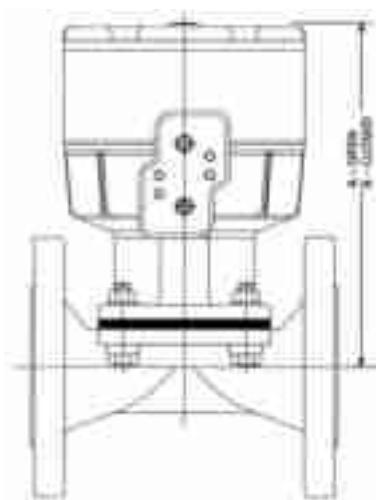

SSC actuator

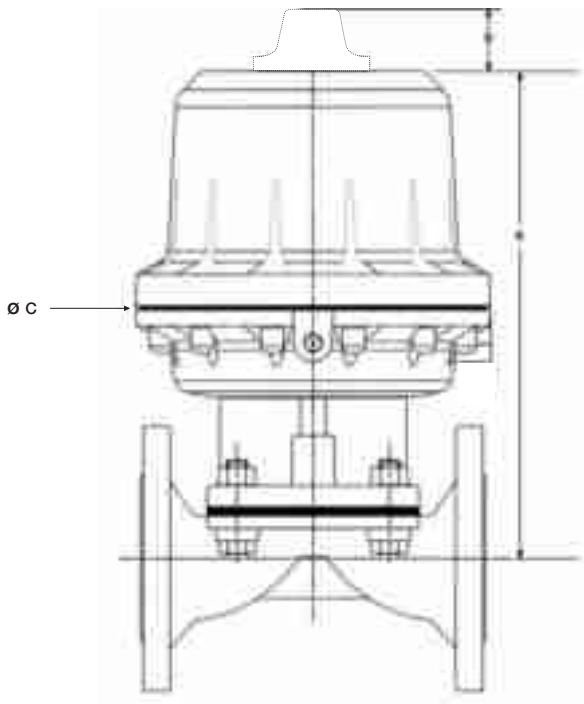

ECX spring closing actuator

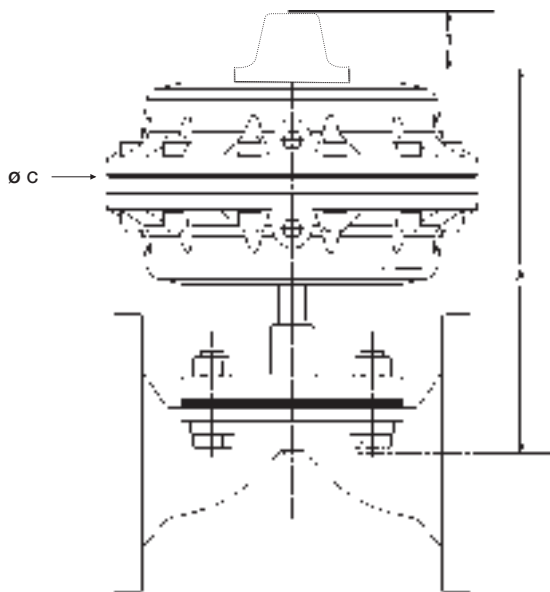

ECX double acting and spring opening actuator

ECX/SO

Size DN	A	B	C
S-Series			
65	245	55	266
80	267	55	266
100	305	55	266

ECX/SO

Size DN	A	B	C
H-Series			
100	359	67	360
125	373	67	360
150	379	67	360

ECX/SC

Size DN	A	B	C
Heads F1, F2 & F3			
65	359	55	266
80	370	55	266
100	417	55	266

ECX/SC

Size DN	A	B	C
Heads G1, G2 & G3			
65	399	55	266
80	410	55	266
100	458	55	266

ECX/SC

Size DN	A	B	C
Heads H1, H2 & H3			
100	560	67	360
125	576	67	360
150	593	67	360

ECX/DA

Size DN	A	B	C
S-Series			
65	246	55	266
80	257	55	266
100	296	55	266

ECX/DA

Size DN	A	B	C
H-Series			
100	355	67	360
125	369	67	360
150	375	67	360

Note: Varying line and operating pressures are accommodated by head models L and S. For Performance refer to our technical data sheets.

Note: Dimension 'B' is for optional indicator on ECX models.

TECHNICAL DATA

ES Modular/EV Actuator Dimensions

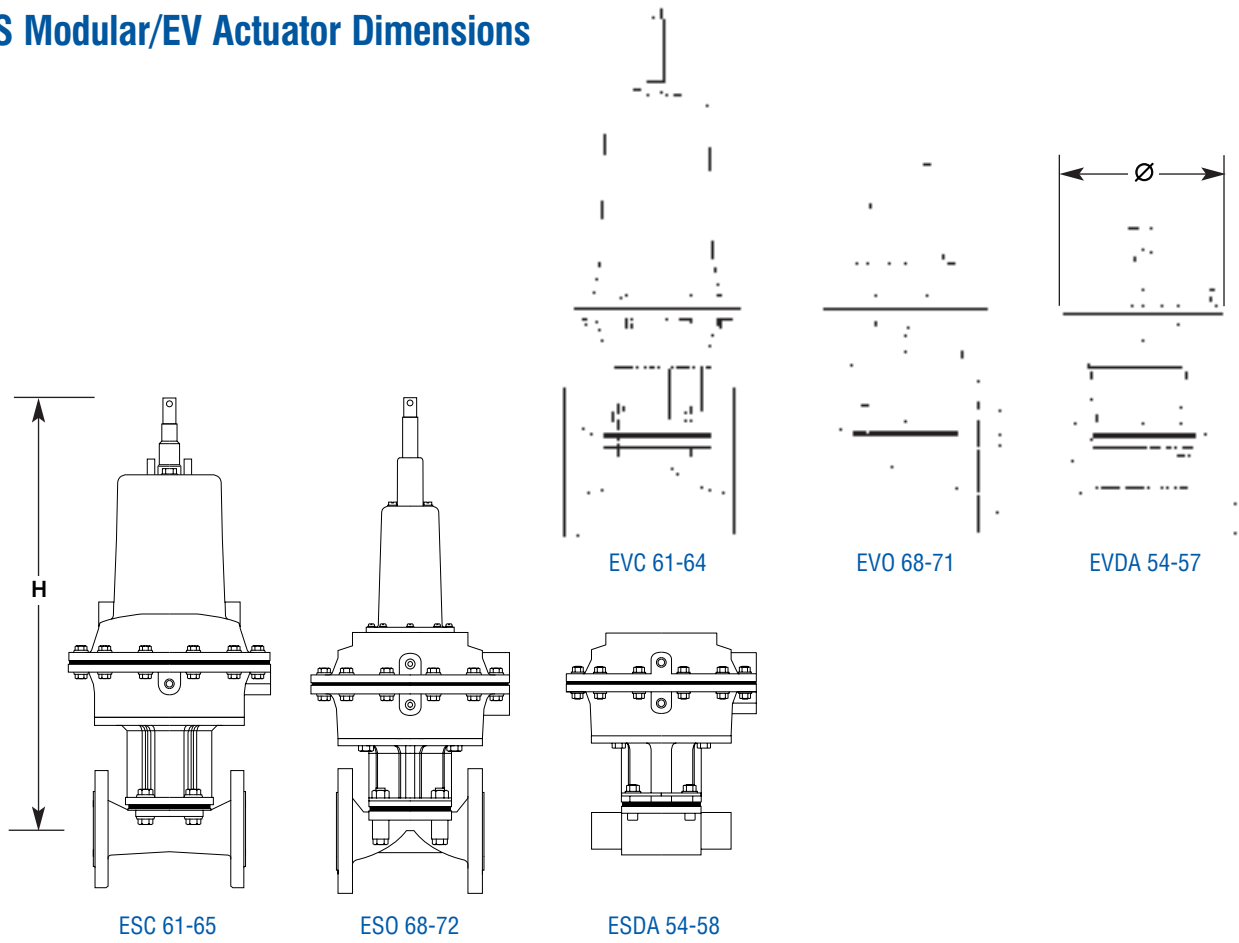

	Model	Δ	H (Type A Valve) – Size in mm																					
			15	20	25	32	40	50	65	80	100	125	150											
Fail Safe Spring CLOSING	ES 61	169	408	413	423	435	461																	
	EV 62	260			462	476	501	501	503															
	EV 63	316					700	729	732	756														
	EV 64	425								784	800	828	895											
	ES 65	549									1031	1059	1125											
Fail Safe Spring OPENING	ES 68	169	378	383	393	406	432																	
	EV 69	260			497	511	537	536	538															
	ES 70	316				773	783	786	810															
	EV 71	425							763	786	813	881												
	EV 72	549								879	907	974												
DOUBLE ACTING	ES 54	169	155	160	170	183	209																	
	ES 55	260			222	235	246	259	271															
	ES 56	316					306	315	318	357														
	ES 57	425								336	363	378	444											
	ES 58	549									382	410	479											

			h (Type KB Valve) – Size in mm										
			15	20	25	32	40	50	65	80	100	125	150
Fail Safe Spring CLOSING					480		480						
					520		521	518	547				
							740	765	797	827			
									841	871	847	962	
											1102	1078	1193
Fail Safe Spring OPENING					450		450						
					556		557	555	582				
							794	819	850	881			
									827	857	833	948	
											950	926	1041
DOUBLE ACTING					227		227						
					280		281	280	307				
							326	351	382	413			
									400	430	406	521	
											453	429	544

Δ = Actuator Diameter/Width H = Actuator Height
 Dimension table shows in mm diameter/width of actuators and the maximum height of the actuator from the centre of the valve flange or pipeline.

Note
 All dimensions are based on unlined bodies and bare shaft actuators. Add on handwheel dimensions are below (ES Modular only)

Actuator	Add-on
68/69/70	+14mm
61/62/63	+14mm
71/64	+18mm

Saunders Diaphragm Valves

Typical Applications

The table shows typical application areas for Saunders diaphragm valves under four categories, Abrasive, Corrosive, Industrial and Aseptic.

ABRASIVE	CORROSIVE	INDUSTRIAL	ASEPTIC
Gold Mining	Chlor-Alkali	Marine	Biotechnology
Cement	Iron and Steel	Vegetable Oil	Pharmaceuticals
Copper Mining	Sulphuric Acid	Paints	WFI
Ceramics	Effluent treatment	Fire Fighting	Fine Chemicals
FGD	Potable Water	Tanning	Chromatography
Sugar	Pulp & Paper	Oil Production	Cosmetics
Coal Slurry	Basic Chemicals	Automobile	Ultra Filtration
Phosphate	Acids and Alkalis	Air	Clean Water
Sand	Organics	Effluent	CIP
Fertilisers	Toxic Fluids	Gases, Fuels	Yeast
Titanium dioxide	Nitric Acid	Dye Liquors	Food & Beverage
Sewage			Soap

Abrasive

- ◆ Minerals processing, chemicals, fertilisers, china clay, paper, power generation are some of the industries that rely on Saunders KB Type diaphragm valves to withstand a wide variety of abrasive service conditions.
- ◆ Ores – phosphate rock or bauxite in aggregate form, slurries such as gypsum in power plant de-sulphurisation, powders – titanium dioxide in pigment application are typical service examples.
- ◆ Applications requiring a combination of corrosion and abrasion resistance, such as phosphate rock/sulphuric acid, together with reliability and long service life are also well catered for by the Saunders KB range.

Corrosive

- ◆ Corrosion is estimated to cost worldwide industry 300 billion Euros every year. Every process industry sector handles corrosive fluids to a smaller or greater extent.
- ◆ Saunders have expertise and unrivalled experience in corrosive applications.
- ◆ Continuous development of 'in-house' materials technology has resulted in the current extensive range of valve options including elastomer and fluoropolymer linings, designed to combat corrosion.

Industrial

- ◆ Saunders valves are widely used on utility (air, water, and gas) service lines. Also, as most process plants have an effluent treatment system there are many applications where Saunders valves can be used successfully: –
- ◆ The Food Industry – Saunders valves are widely used on margarine, yogurt and corn processing plants.
- ◆ In the Transport Industries Saunders have found success in the marine sector as mentioned earlier, in the automobile sector on service lines and paint coating systems and on road and rail tankers.

Aseptic

- ◆ Saunders is a key player in the evolution of high purity valve technology.
- ◆ The top ten pharmaceutical companies in the world head our international customer base.
- ◆ Saunders extensive range of valves designed for the pharmaceutical industry are detailed in other dedicated literature available from us.



Actuation Accessories

Overview

MODEL	SIZE RANGE	STYLE	MATERIAL	SOLENOID	SWITCH BOX	POSITIONER	AIR FILTER	HANDWHEEL
EC	DN8-50	A, AFP	PES	✓	✓	✓	✗	✗
SSC	DN8-50	A, AFP	316 C12	✓	✓	✓	✗	✓
ECX	DN65-150	A, AFP	SiAl	✓	✓	✗	✓	✗
EV	DN15-150	A, AFP, KB	SiAl	✓	✓	✓	✓	✗
ESM	DN15-150	A, AFP, KB	SiAl	✓	✓	✓	✓	✓

✓ = Available and ✗ = Not available

Solenoid Valves

A wide range of locally mounted banjo solenoid valves can be fitted to the Saunders actuator range with a manual override option and various hazardous area classifications. The solenoid range should cover all your requirements.

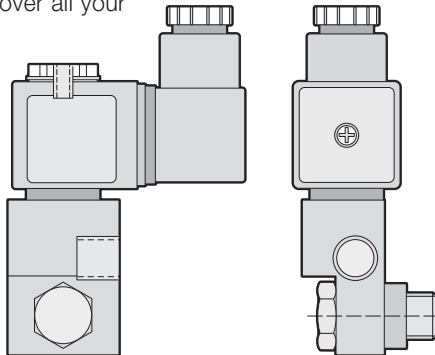

Mini Positioner

For control application on the EC and SSC the VIAPOS mini offers both pneumatic, electro-pneumatic and digital inputs with sensor feedback option and linear mounting design providing a neat control solution.

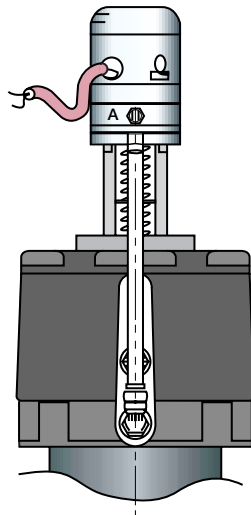

Module

This highly modular switchbox option is available for EC/SSC & ECX actuator ranges. The switchbox offers a wide range of V3 mechanical and proximity sensors with space for up to 4 switch, integral solenoid valve & ASI interface*.

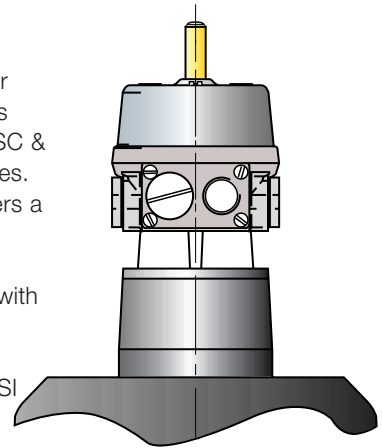

*ASI interface can be retro-fitted

Opti-SET Switchbox

Suitable for EC and SSC Actuators. The Opti-SET is an easy to set switchbox. Available with two mechanical or proximity switches and intrinsically safe Option. Manufactured from carbon filled Nylon 66.



ES Positioner

Providing precise control of the flow through the valve. This long life corrosion resistant range suits a wide variety of applications with reliability and accuracy. Available as pneumatic electro pneumatic intrinsically safe and explosion proof, together with a variety of feedback options.

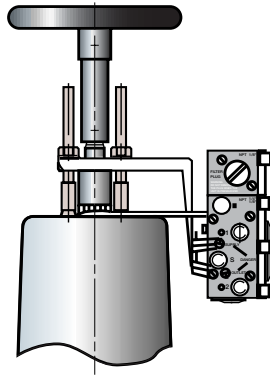

Shown mounted to ESM Actuator

EC & SSC Limit Open Stop

The EC/SSC limit open stop can be supplied to order and offers a fully adjustable travel stop. With the removal of the plastic indicator the limit stop is easily accessible.

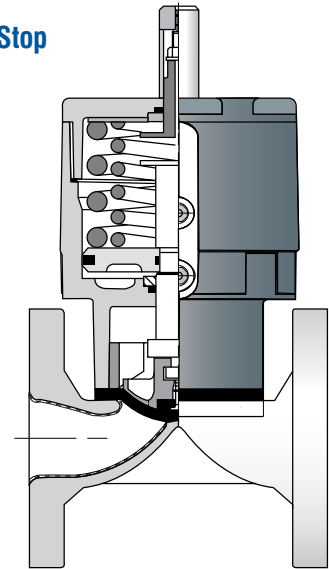

007 Switchbox

Manufactured from polyester coated aluminium. This switchbox is used for the ESM and EV linear actuators. It has the capability for up to 4 switches and can incorporate internal solenoid valve and ASI system.

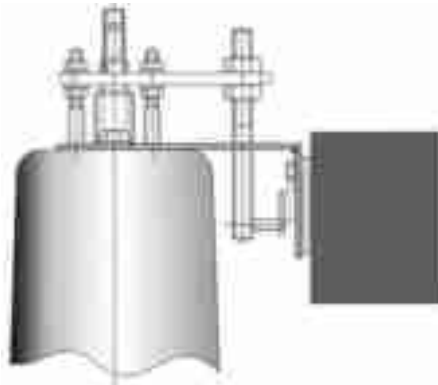

Shown mounted to ESM Actuator

SSC Switchbox

Manufactured from 316 stainless steel. This switchbox is used for the EC and SSC compact actuator. It is available with either mechanical switches or proximity sensors.

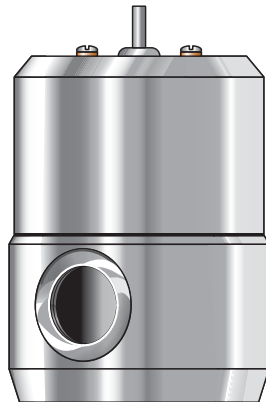

SSC M/O

For extra security the SSC can be supplied with an emergency manual over-ride manufactured from stainless steel. Please contact Crane for further information.

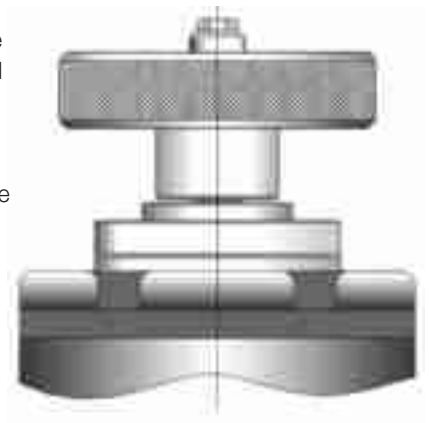

Software to Aid the Process Engineer in Selecting Saunders Products

Engineering Selection Tools

- ◆ Material Selection
- ◆ On/Off Actuation
- ◆ Technical Data Sheets

The Saunders Material Selection

Database lists over 1,000 process chemicals – just enter the temperature and concentration and a recommendation for the body and diaphragm material is selected.



Saunders Data Sheets are available on CD for fast and accurate detailed information on the industrial valve range.

The electronic data manual contains over 100 individual technical data sheets to assist you with the selection of the valve.

On/Off Actuation Selection

By simply entering your process data into the selection boxes the program sizes the actuator to suit your specific requirements.

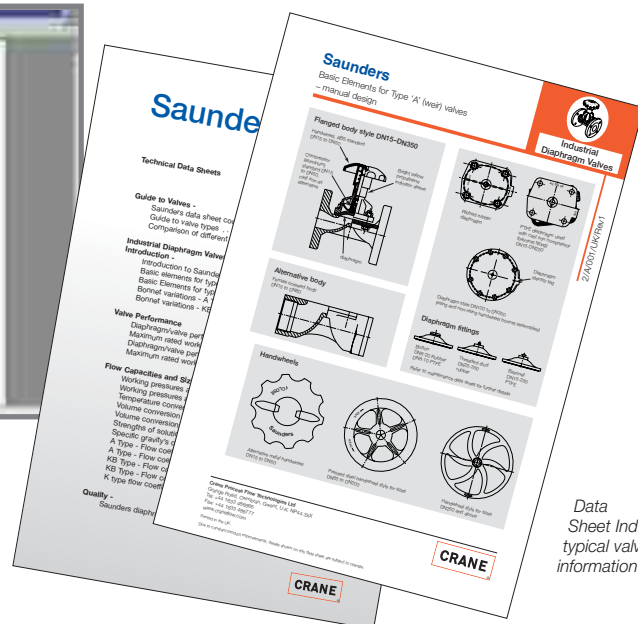
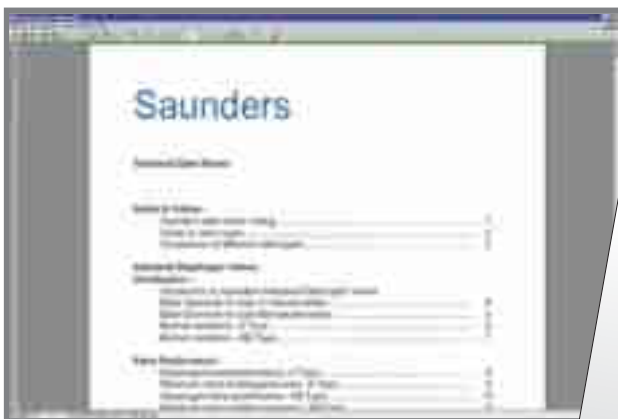

Data Sheet Index and typical valve information

Quality Statements and Approvals

ISO 9001
Certificate of
Registration



Certified Quality from Crane Process Flow Technologies Ltd.

The Complete Approach to Quality

Quality Management system registered to ISO 9001 standard in which our R & D and manufacturing process are optimised to maintain our product quality and service.

TUV-Merkblatt HPO Qualification for our product manufacturing and certification.

Certified compliance to the European Pressure Equipment Directive 97/23/EC authorising Crane Process Flow Technologies Ltd to CE mark relevant valve products.

International product approval from authorities such as Bureau Veritas, American Bureau of Shipping.

Polymer/Rubber materials certified as meeting the requirements of FDA, USP & WRAS.

PED
Certificate
of Conformity



QUALITY ASSURANCE APPROVALS

BS EN ISO 9001 : 2000

TÜV AD-2000-MERKBLATT-HPO
TÜV AD-2000-MERKBLATT-A4



COMPLIANCE WITH
FDA CODE 21

TNO CERTIFICATION
3A
cGMP
USP 23

Product and System Approvals Examples

ISO 9001

PED 97/23/EC

ATEX Directive (94/9/EC)

WRAS (Water Regulations Advisory Scheme)

Lloyds Register of Shipping

Det Norske Veritas

Bureau Veritas

U12 Marine Safety Agency

American Bureau of Shipping

Food & Drug Administration (FDA)

United States Pharmacopeia (USP)

Valve Ordering Information



A and KB Valves

Type	Style	Size	End Specification	Body Material	Diaphragm	Operating Mechanism
I						

Industrial

A = Weir A Type
B = KB Type

Refer to pages 46, 47 and 48

DN8	008
DN10	010
DN15	015
DN20	020
DN25	025
DN32	032
DN40	040
DN50	050
DN65	065
DN80	080
DN100	100
DN125	125
DN150	150
DN200	200
DN250	250
DN300	300
DN350	350

BS5156 Length Flanged	
BS10 Table D	F1
BS4504 PN10	F3
ANSI 125/150	F4
JIS 10K	F5
PN10 4-Bolt	F6
Screwed Female	
BS21 Rp	S1
BS21 Rc	S2
API/NPT	S3
DIN Length Flanged	
DIN ND10	D1
DIN ND10-4 Bolt	D2
US Length Flanged	
ANSI 125/150	U1

Cast Iron		SG Iron	
Rubber Diaphragm	CX	Rubber Diaphragm	ZX
PTFE Diaphragm	CW	PTFE Diaphragm	ZW
Butyl Lined	CB	Butyl Lined	ZB*
Hard Rubber	CC	Hard Rubber	ZC*
HRL for PTFE	CD	HRL for PTFE	ZD*
HRL Full Face	CJ	HRL Full Face	ZJ
HRL Full Face for PTFE	CK	HRL Full Face for PTFE	ZK
Soft Rubber	CS	Soft Rubber	ZS*
Neoprene Lined	CN	Neoprene Lined	ZN*
Glass Lined	CG	ETFE	ZE
PTFE	CT	PFA	ZF
Stainless Steel		Polypropylene	ZP
Rubber Diaphragm	SX	Galvanised	ZZ
PTFE Diaphragm	SW	Carbon Steel	
Gunmetal		Rubber Diaphragm	QX
Rubber Diaphragm	GX	PTFE Diaphragm	QW
PTFE	GW	Hard Rubber L	QC
		Hard Rubber L for PTFE	QD

* DIN bodies only

PTFE	CODE
214/300	P1
214/226	P3
214/425	P2
214K/425	P7
Silicone	
500	Q1
Viton	
226	V1
Natural	
AA	A1
Q	A2
Butyl	
300	B1
300 vac	B2
Nitrile	
C	C1
Cvac	C2
EPM	
425	E2
Hypalon	
237	H
286 fire dia.	H3
Neoprene	
HT	N1

WFB Valves



Type	Style	Size	Flange	Material	Diaphragm	Operating Mechanism
I	W					

Industrial

WFB

040/065 mm

Model 9	A
Model 4	B
Model 11	C
Model 2	D

F1
F3
F4

Gunmetal	G
SG Iron	Z

Hypalon 286 = H3

Gunmetal	H01
SG Iron	H02

For standard options, refer to current price list



Sub Assembly Manual Bonnets Only

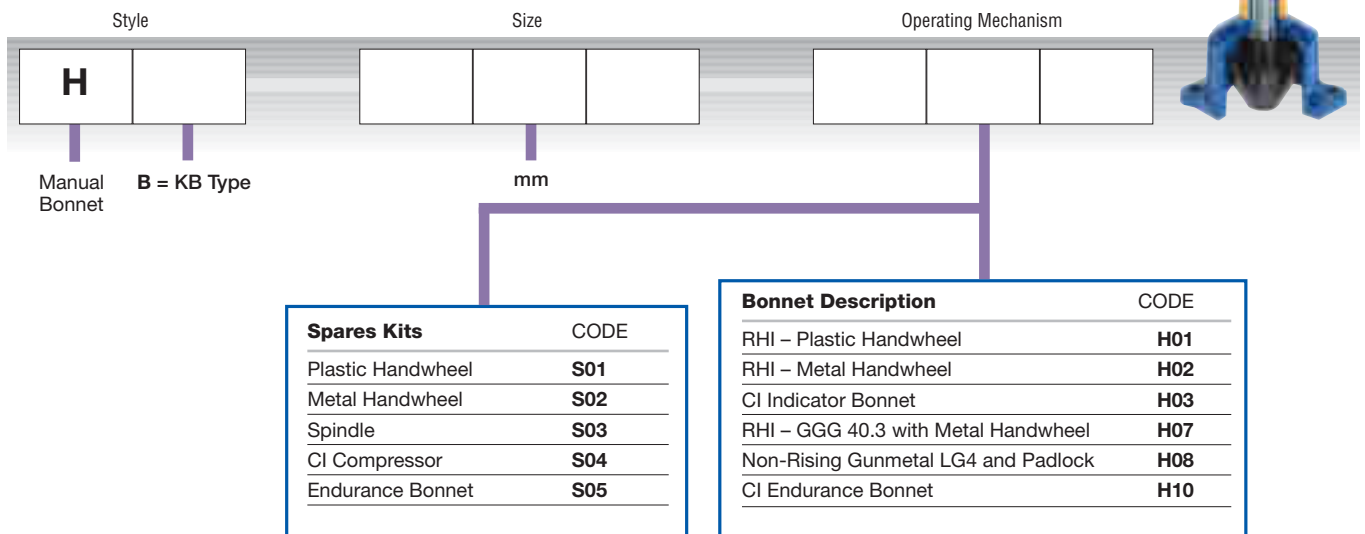
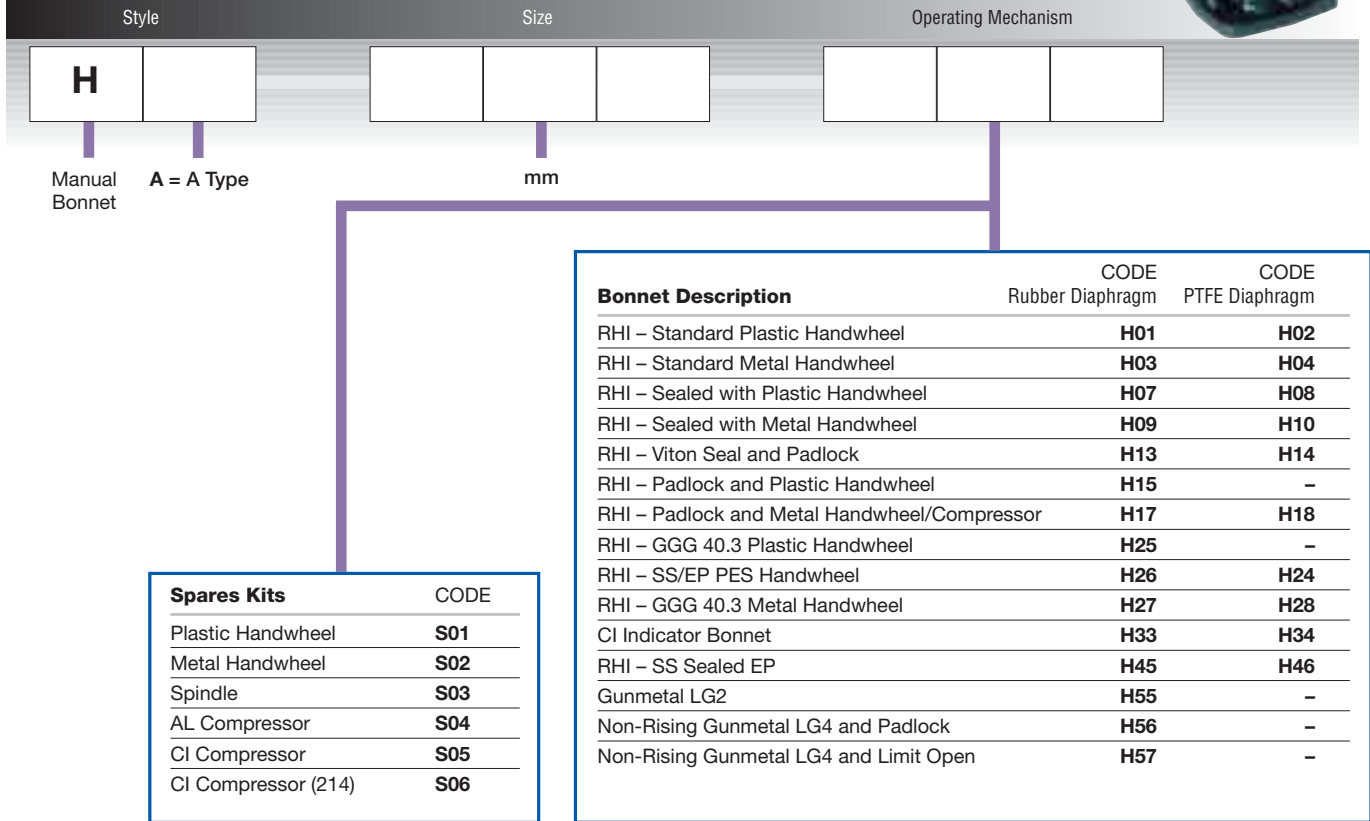

Actuation Options

Type EC Compact Pneumatic Actuators

Style	Size	Type	Mode of operation	Dia	Air Connection	Slotted	Limit stops
A -							
Diaphragm Type A	mm	C = EC	4 = 4 bar Spring Closed 6 = 6 bar Spring Closed O = Spring Open D = Double Acting	R = Rubber P = PTFE	B = BSP N = NPT	Y = Yes N = No	N = None O = Limit Open

AA = Sizes 8mm to 50mm



Type ECX Diaphragm Valve Actuators

Style	Size	Type	Mode of operation	Dia	Visual indicator	Limit stops
A A		X				N
Diaphragm A Type	mm	ECX	F2, F4, G2, G3, G4, G5, H2, H4, H5 = Spring Closed OS, OH = Spring Open DS, DH = Double Acting	R = Rubber P = PTFE	Y = Yes N = Only when accessories are used	N = None



EC Actuator Opti-SET Switchbox Options

Type	Size	Switchbox	Module
V C		B E	
V = Accessory C = EC	mm		Conduit Entry O = Metric P = PG N = NPT Switch Type M1 = V3 Mech. M2 = V3 Mech. Gold Plated M8 = V3 Mech. Gold plated (ATEX) P2 = ProxSwitch Intrinsically Safe (ATEX) P6 = ProxSwitch 3 Wire NPN P7 = ProxSwitch 3 wire PNP P8 = ProxSwitch 2 wire NPN/PNP (5-60Vdc) P9 = ProxSwitch 2 Wire NPN/PNP (5-36Vdc)



EC Actuator Module Switchbox Options

Type	Size	Switchbox	Module
V C		B M	
V = Accessory C = EC	mm		Conduit Entry O = Metric P = PG N = NPT Switch Type M1 = V3 Mech. M2 = V3 Mech. Gold Plated M8 = V3 Mech. Gold Plated (ATEX) P2 = ProxSwitch Intrinsically Safe (ATEX) P6 = ProxSwitch 3 Wire NPN P7 = ProxSwitch 3 wire PNP P9 = ProxSwitch 2 Wire NPN/PNP Switch Quantity 1 = One 2 = Two Pneumatic Control 0 = None 1 = Single/Double Acting 1/8" BSP 2 = Single/Double Acting 1/8" NPT 3 = Single Acting Manifold 1/8" BSP 4 = Single Acting Manifold 1/8" NPT Solenoid Voltage 0 = None 1 = 220/240v AC 50/60Hz 2 = 110/120v AC 50/60Hz 3 = 24v DC 5 = Intrinsically safe 24v DC (ATEX)



EC Actuator SS 'Compact' Switchbox

Type	Size	Switchbox	Module
V C		B S	
V = Accessory C = EC	mm		Conduit Entry O = Metric N = NPT Switch Type M1 = V3 Mech. M2 = V3 Mech. Gold P6 = ProxSwitch 3 Wire NPN P7 = ProxSwitch 3 wire PNP P9 = ProxSwitch 2 Wire NPN/PNP Switch Quantity 1 = One 2 = Two Pneumatic Control 0 = None Solenoid Voltage 0 = None



Type ES Modular Valve Actuators

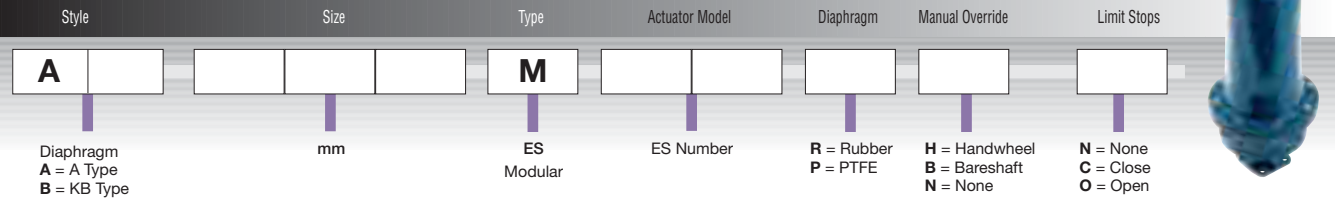

Type EV Diaphragm Valve Actuators

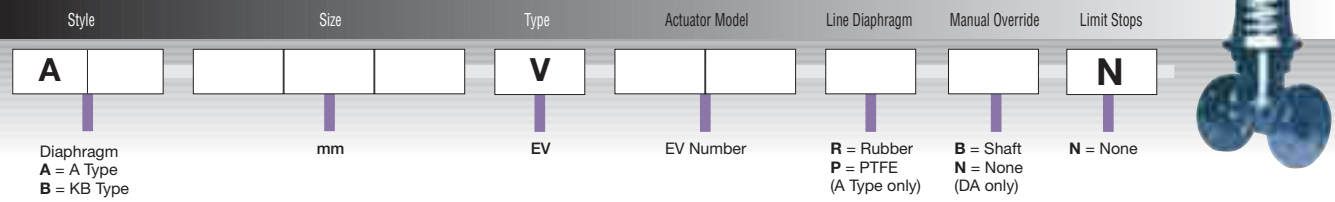

ES Actuator Positioner Options

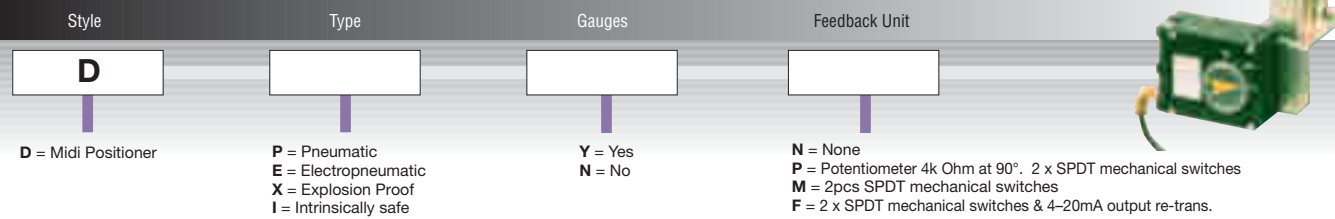

ES Actuator – 007 Switchbox Options

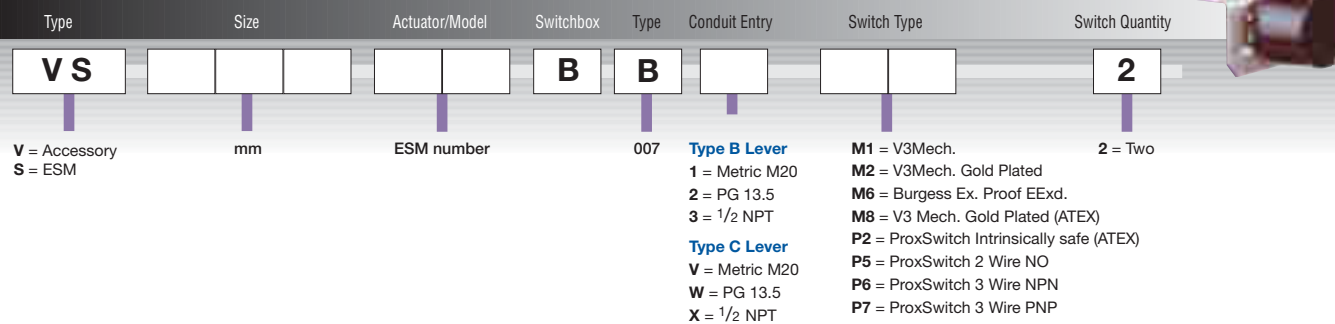

EV Actuator – 007 Switchbox Options

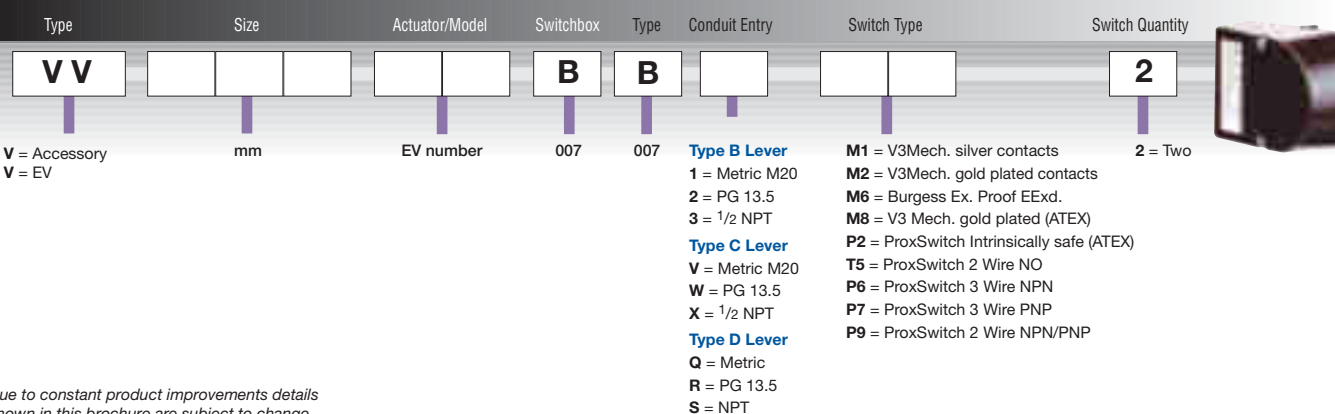

Due to constant product improvements details shown in this brochure are subject to change

Notes





Crane Process Flow Technologies Ltd.

Grange Road

Cwmbran, Gwent NP44 3XX

UNITED KINGDOM

Tel: +44 163 348 6666

Fax: +44 163 348 6777

www.cranechempharma.com

CRANE

ChemPharma Flow Solutions

Austria
Tel.: +43-2236-682-0
Fax: +43-2236-4353

Germany
Tel.: +49 211 5956-0
Fax: +49 211 5956-111

India
Tel.: +91-20-26050922-26
Fax: +91-20-26050927

Belgium
Tel.: +32-10-8184-44
Fax: +32-10-8184-58

Italy
Tel.: +39-039-2704-280
Fax: +39-039-2704-450

UAE
Tel.: +971-4-8864949
Fax: +971-4-8864950

brands you trust.

CRANE ChemPharma Flow Solutions Include: Pipe - Valves - Fittings - Actuators - Pumps

DEPA

ELRO

PSI
LINED PIPING SYSTEMS

RESISTOFLEX

ResistoPure

revo

Saunders
the science inside

XOMOX

© Copyright 2009 Crane Process Flow Technologies GmbH.
Crane®, DEPA®, RESISTOFLEX®, REVO®, SAUNDERS®, XOMOX®
are registered trademarks of Crane Corporation and his subsidiaries.